



Profiles:

Profiles are manufactured from 6063-T5 extruded aluminum with a wall thickness of up to 1/8" allowing for oversized panels. The door systems are available with either powder coat, Kynar or anodized finishes in virtually any color the customer chooses.

Tracking:

There are five types of tracks available to accommodate any flooring conditions, allowing for an almost seamless look with only 3/16" protrusion above the finished floor. All weight is carried on the bottom track, the top track serves as a guide.

Configurations:

These systems can accommodate up to 5 panel per unit.

Hardware:

The wheel carriages are comprised of stainless steel wheels and have a corrosion resistant treatment applied for high performance in coastal regions. Each wheel carriage can support up to 550 lbs . The operating mechanism includes a multi-point lock with a flush handle. The entire door system has specially designed EPDM gaskets to create a totally closed, weather tight system.

Weight:

Each panel weighs approximately 7 to 8 lbs per sq ft depending on overall panel size and glass configuration.

TS30 AW PROFILE:

WIDTH: $2\frac{3}{8}$ "

HEIGHT: $3\frac{3}{16}$ "

GLASS THICKNESS:

1" AND $1\frac{3}{8}$ "

TS30 AW MAX PANEL SIZE:

WIDTH: 60"

HEIGHT: 144"



PANEL CONFIGURATION WITH POCKETS

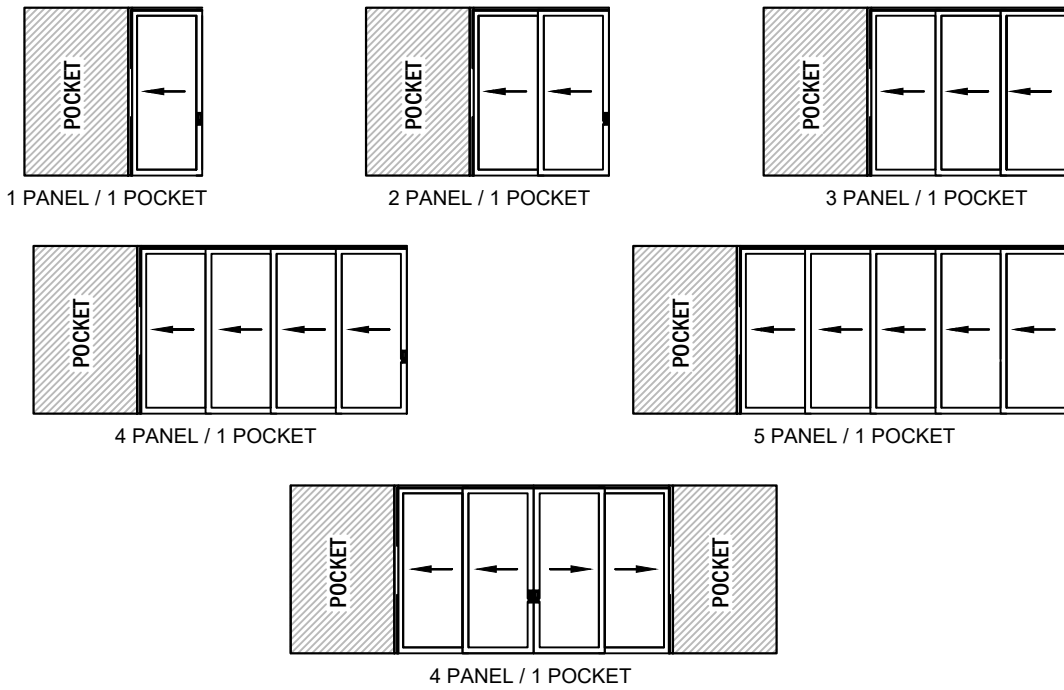

PANEL CONFIGURATION WITH FIXED PANEL

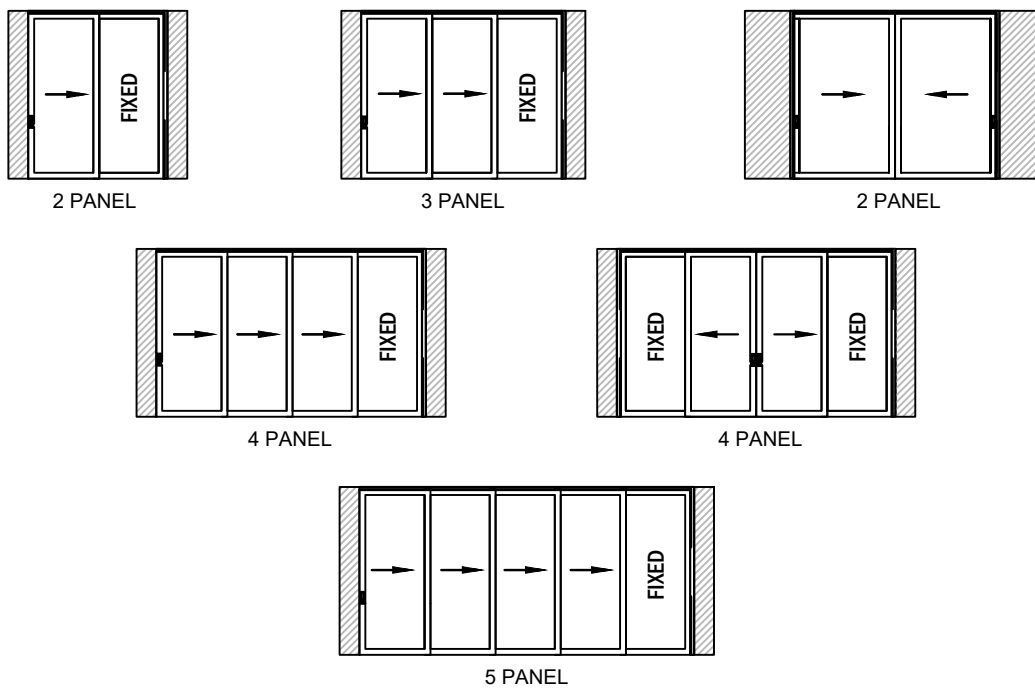



OPTION 1

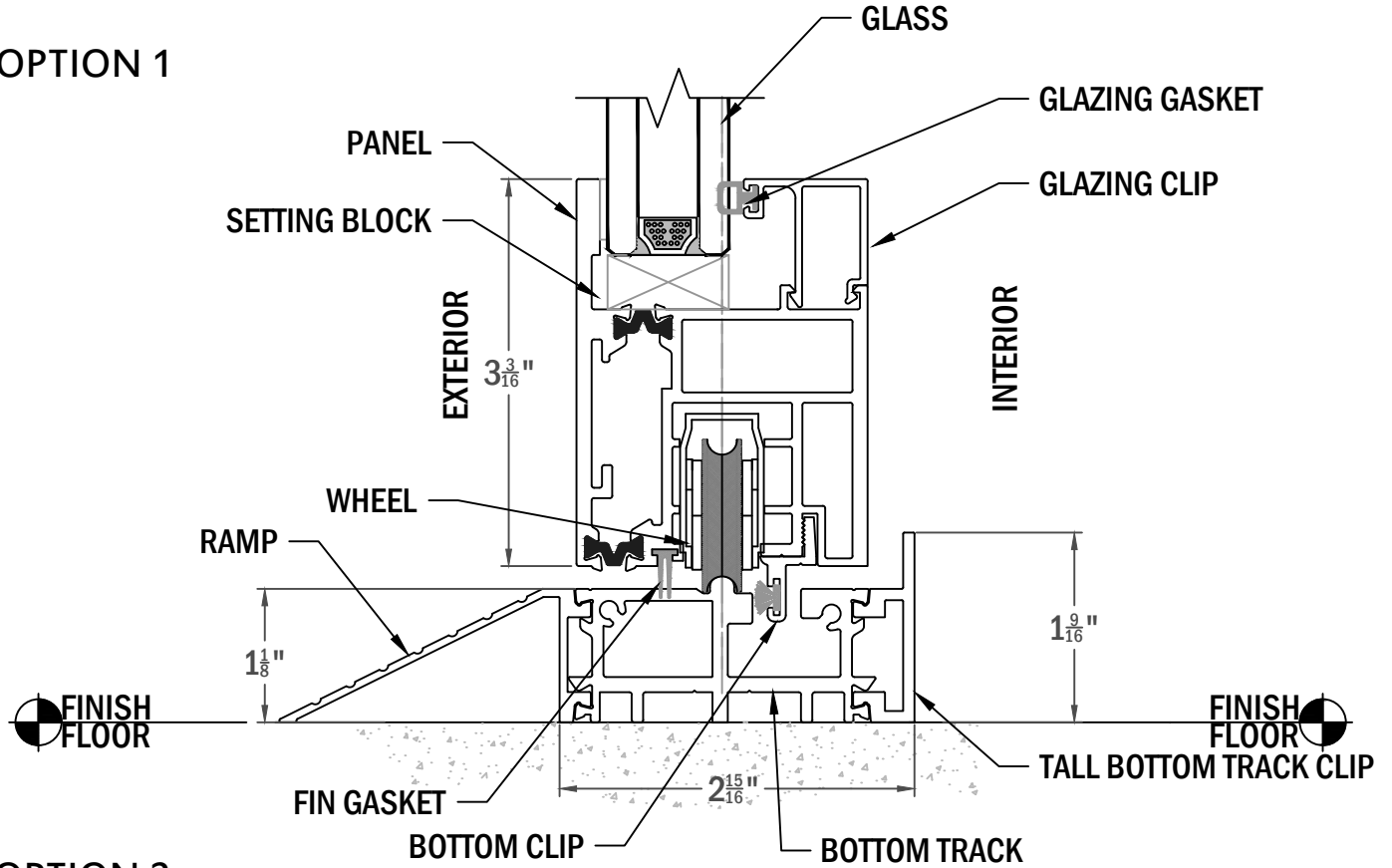

OPTION 2

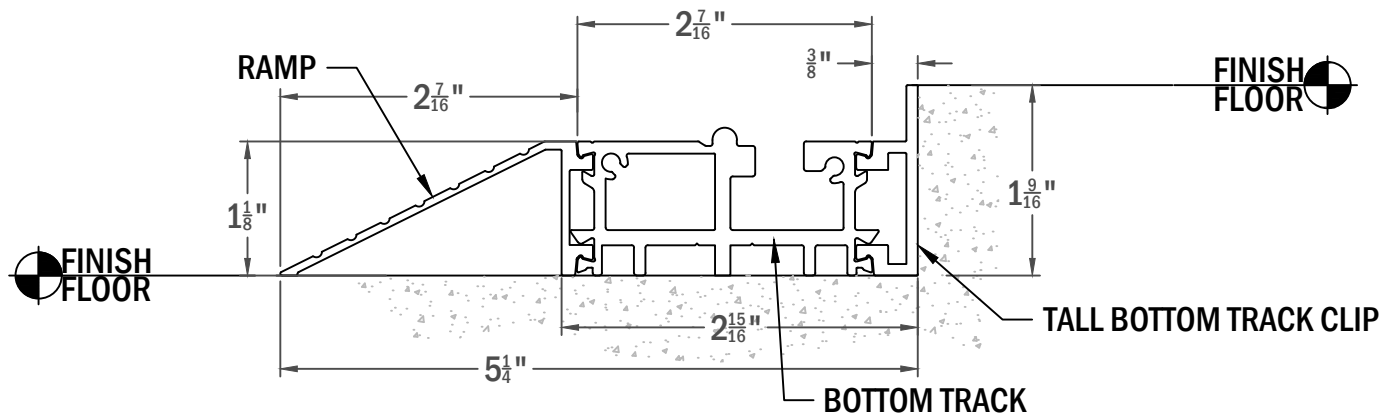

OPTION 3

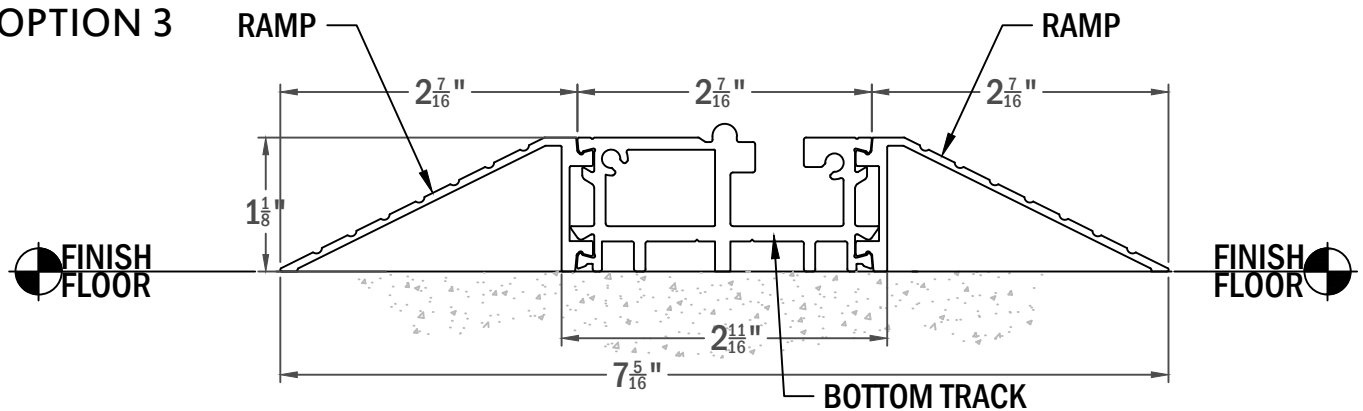



RECOMMENDED TRENCH WIDTH:

- 1 TRACK : $3 \frac{5}{8}$ " WIDE
- 2 TRACK: $6 \frac{9}{16}$ " WIDE
- 3 TRACK: $9 \frac{1}{2}$ " WIDE
- 4 TRACK: $12 \frac{3}{8}$ " WIDE

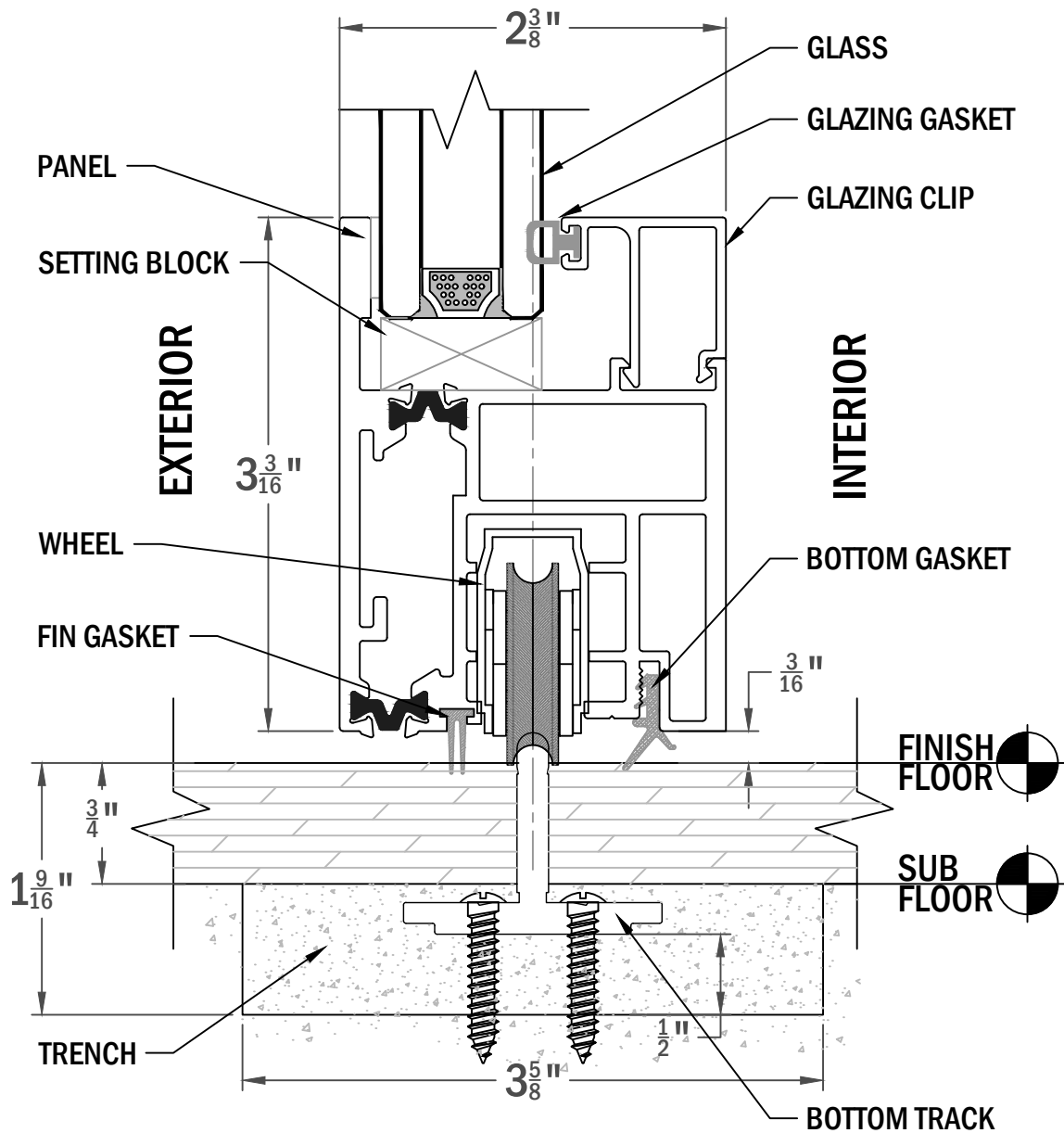



RECOMMENDED TRENCH WIDTH:

- 1 TRACK : $3 \frac{3}{4}$ " WIDE
- 2 TRACK: $6 \frac{11}{16}$ " WIDE
- 3 TRACK: $9 \frac{5}{8}$ " WIDE
- 4 TRACK: $12 \frac{9}{16}$ " WIDE

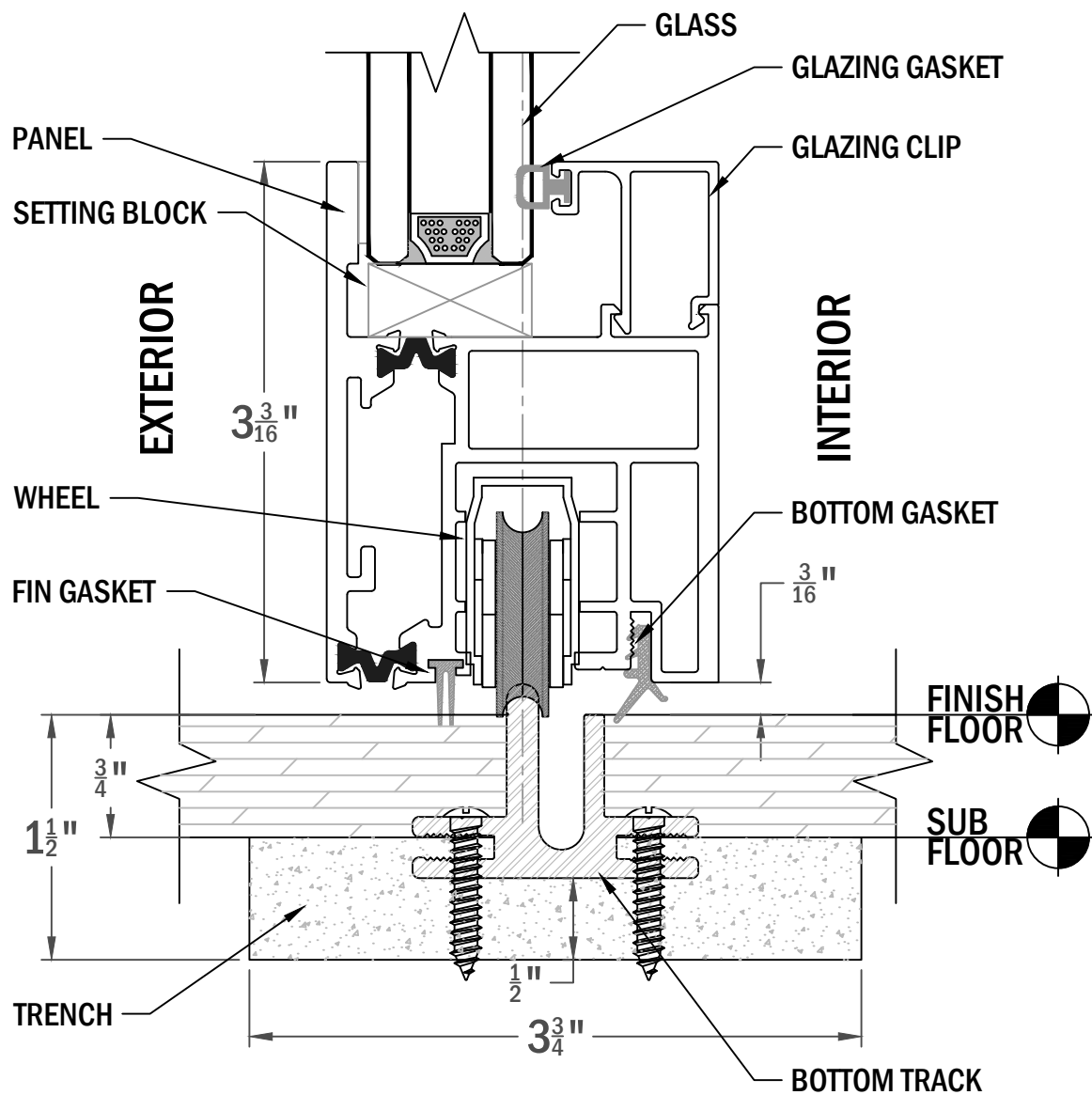



RECOMMENDED TRENCH WIDTH:

1 TRACK : 6 ³/₈" WIDE

2 TRACK: 9 ⁵/₁₆" WIDE

3 TRACK: 12 ¹/₄" WIDE

4 TRACK: 15 ³/₁₆" WIDE

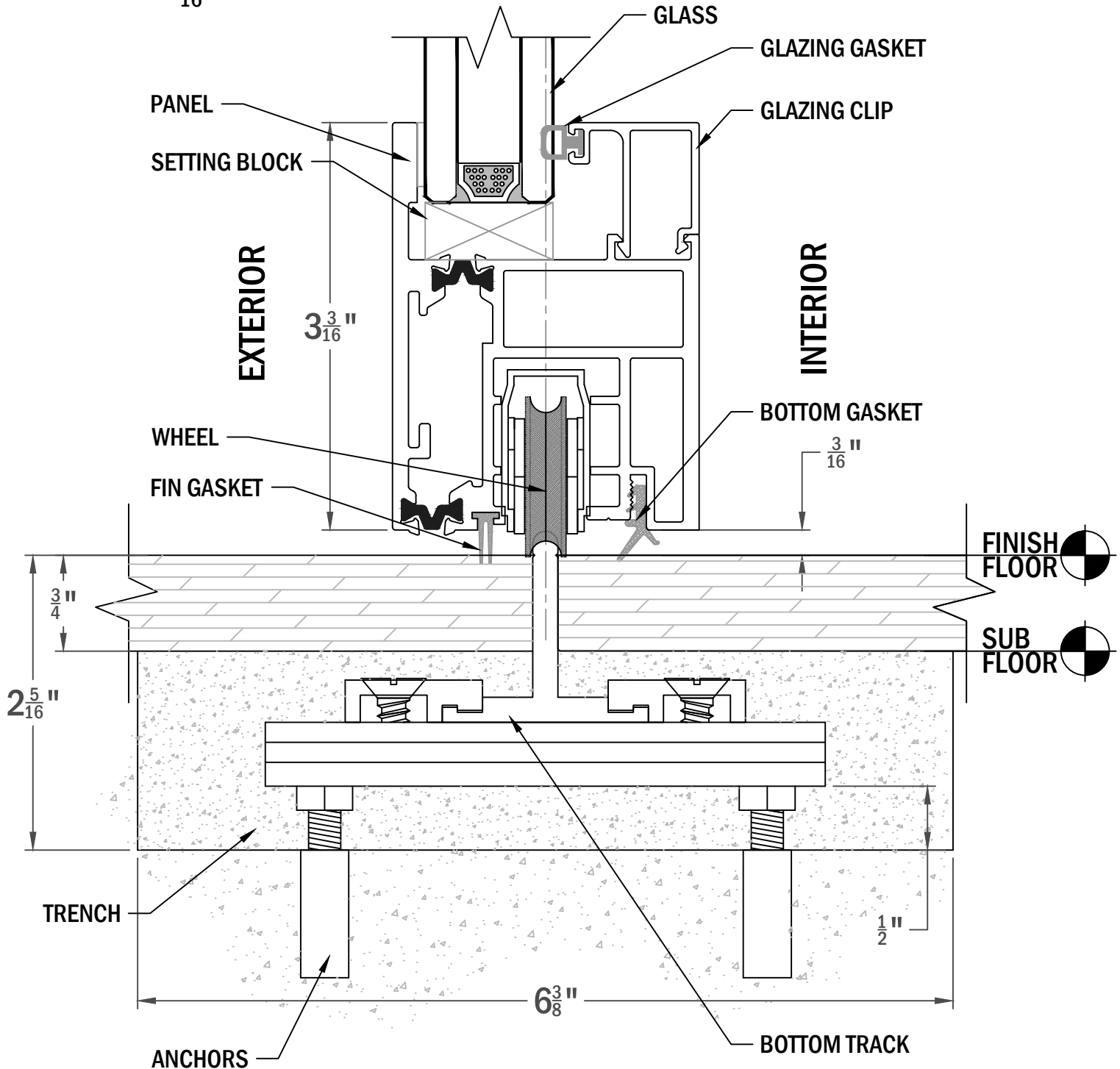



RECOMMENDED TRENCH WIDTH:

- 1 TRACK : 6 ³/₈" WIDE
- 2 TRACK: 9 ⁵/₁₆" WIDE
- 3 TRACK: 12 ¹/₄" WIDE
- 4 TRACK: 15 ³/₁₆" WIDE

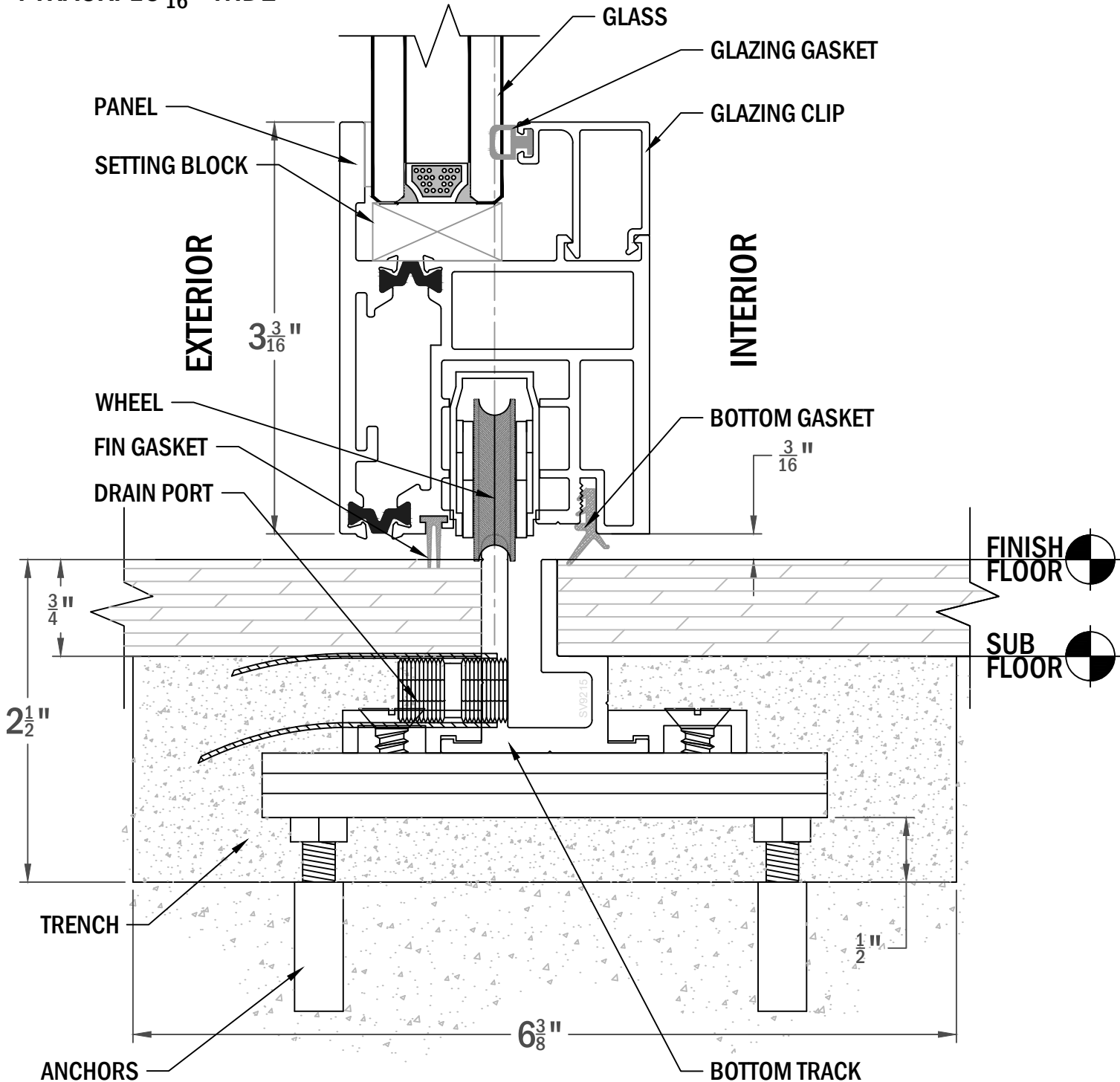



HEADER WIDTH:

- 1 PANEL: $2\frac{15}{16}$ " WIDE
- 2 PANELS: $5\frac{7}{8}$ " WIDE
- 3 PANELS: $8\frac{13}{16}$ " WIDE
- 4 PANELS: $11\frac{3}{4}$ " WIDE

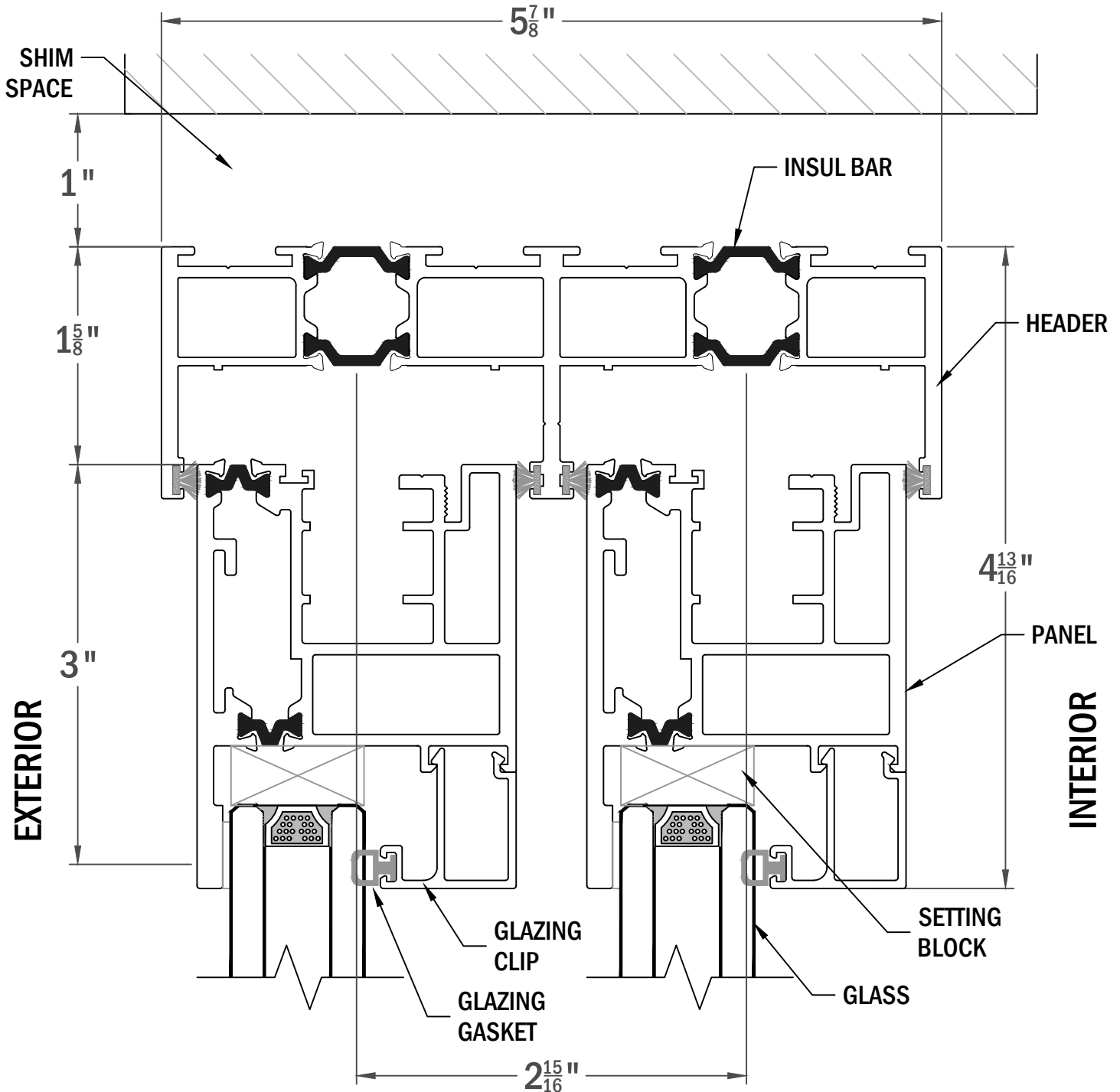



SIDE FRAME WIDTH:

- 1 PANEL: $2 \frac{15}{16}$ " WIDE
- 2 PANELS: $5 \frac{7}{8}$ " WIDE
- 3 PANELS: $8 \frac{13}{16}$ " WIDE
- 4 PANELS: $11 \frac{3}{4}$ " WIDE

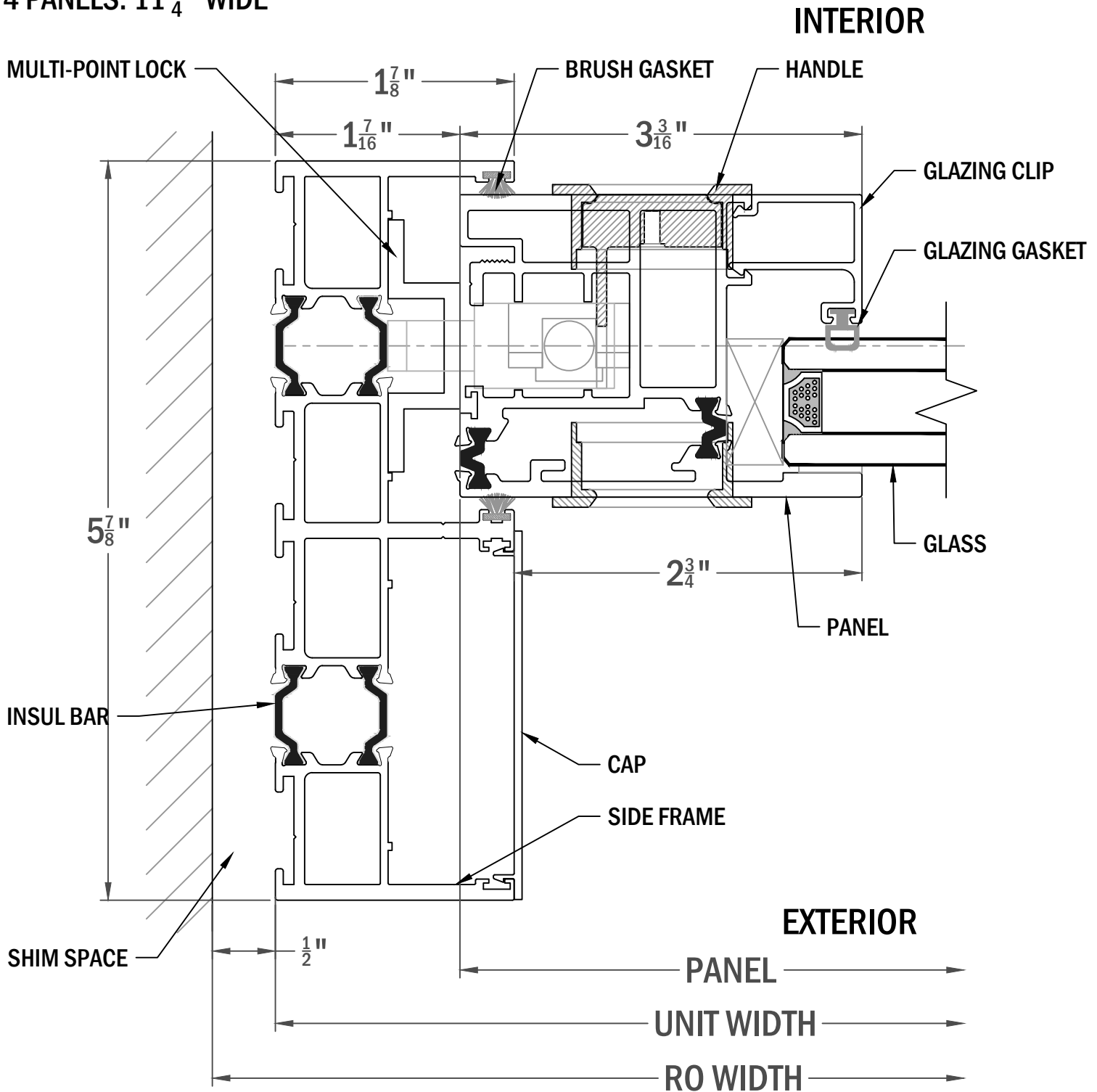

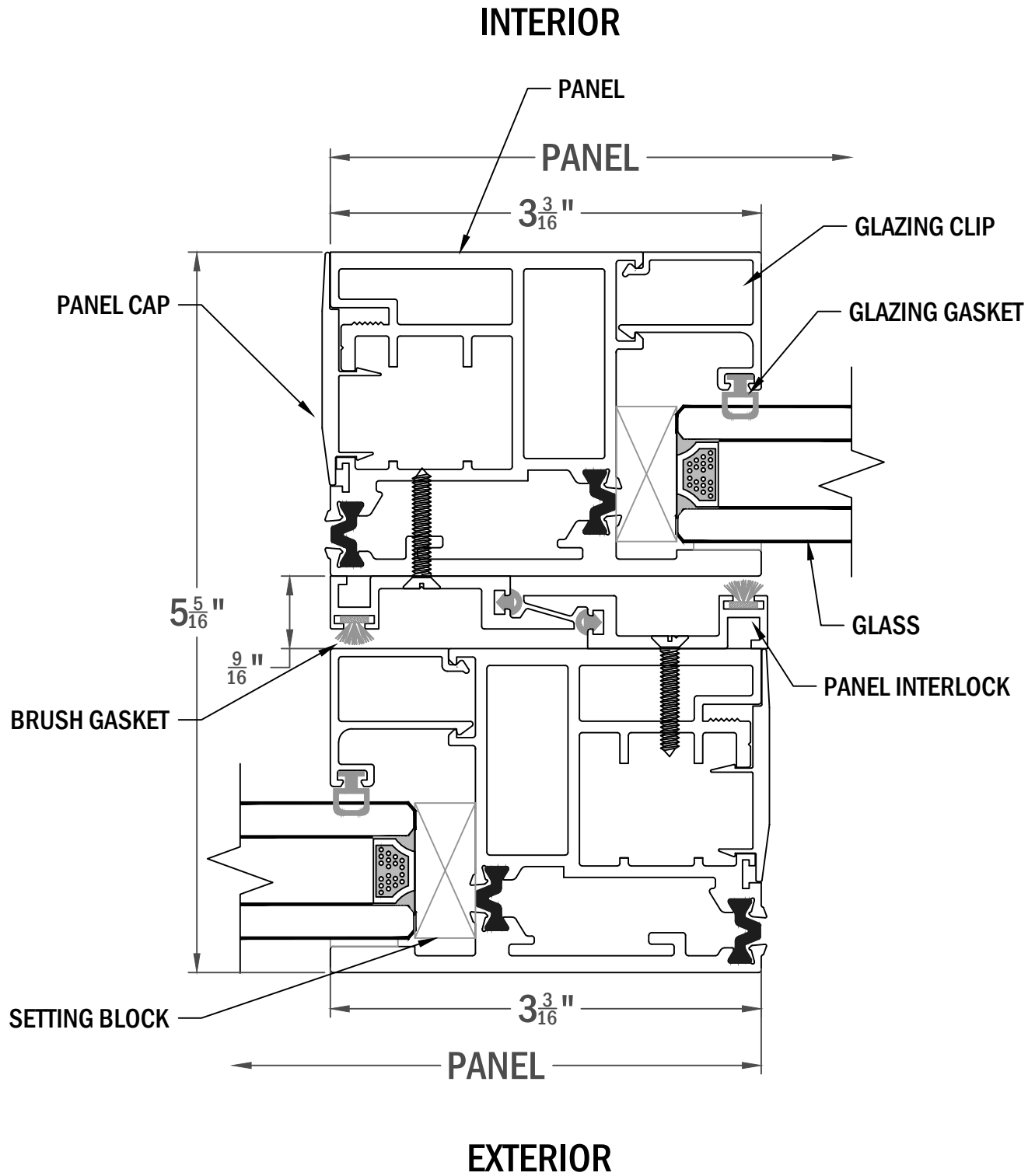

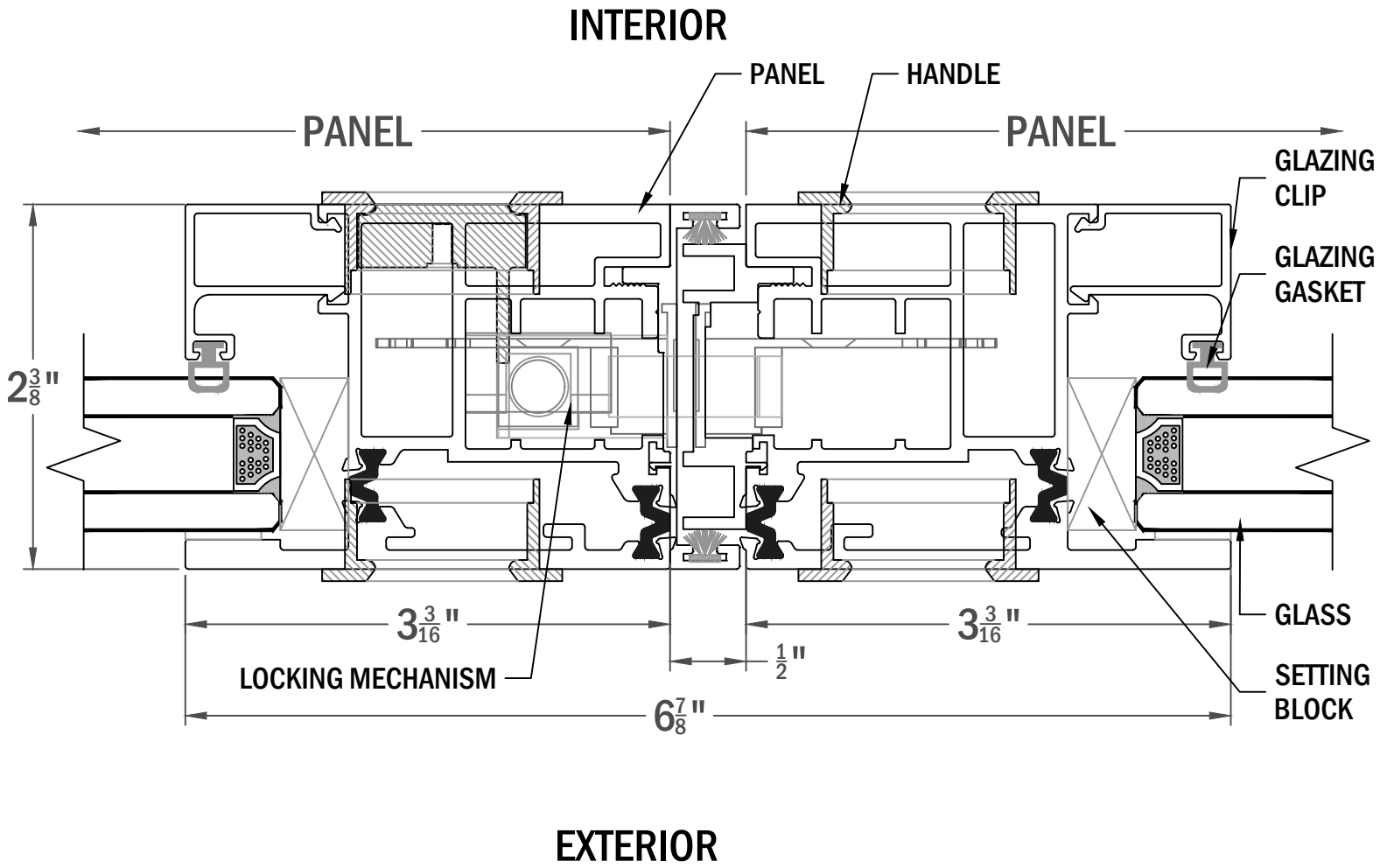



RECOMMENDED POCKET WIDTH:

- 1 PANEL: 2 $\frac{3}{4}$ " WIDE
- 2 PANELS: 5 $\frac{5}{8}$ " WIDE
- 3 PANELS: 8 $\frac{1}{4}$ " WIDE
- 4 PANELS: 11 $\frac{1}{4}$ " WIDE

