

**Profiles:**

Profiles are manufactured from 6063-T5 extruded aluminum with a wall thickness of up to 1/8" allowing for oversized panels. The door systems are available with either powder coat, Kynar or anodized finishes in virtually any color the customer chooses.

**Tracking:**

There are five types of tracks available to accommodate any flooring conditions, allowing for an almost seamless look with only 3/16" protrusion above the finished floor. All weight is carried on the bottom track, the top track serves as a guide.

**Configurations:**

These systems can accommodate up to 5 panel per unit.

**Hardware:**

The wheel carriages are comprised of stainless steel wheels and have a corrosion resistant treatment applied for high performance in coastal regions. Each wheel carriage can support up to 550 lbs . The operating mechanism includes a multi-point lock with a flush handle. The entire door system has specially designed EPDM gaskets to create a totally closed, weather tight system.

**Weight:**

Each panel weighs approximately 7 to 8 lbs per sq ft depending on overall panel size and glass configuration.

**LTS31 AW PROFILE:****WIDTH:** 2  $\frac{3}{8}$ "**HEIGHT:** 3  $\frac{3}{16}$ "**GLASS THICKNESS:****1" AND 1  $\frac{3}{8}$ "****LTS31 AW MAX PANEL SIZE:****WIDTH:** 5'-0"**HEIGHT:** 10'-0"



**PANEL CONFIGURATION WITH POCKETS** (SYSTEM CAN STACK LEFT AND/OR RIGHT)

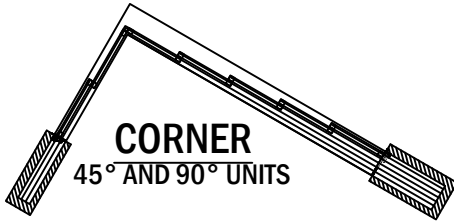
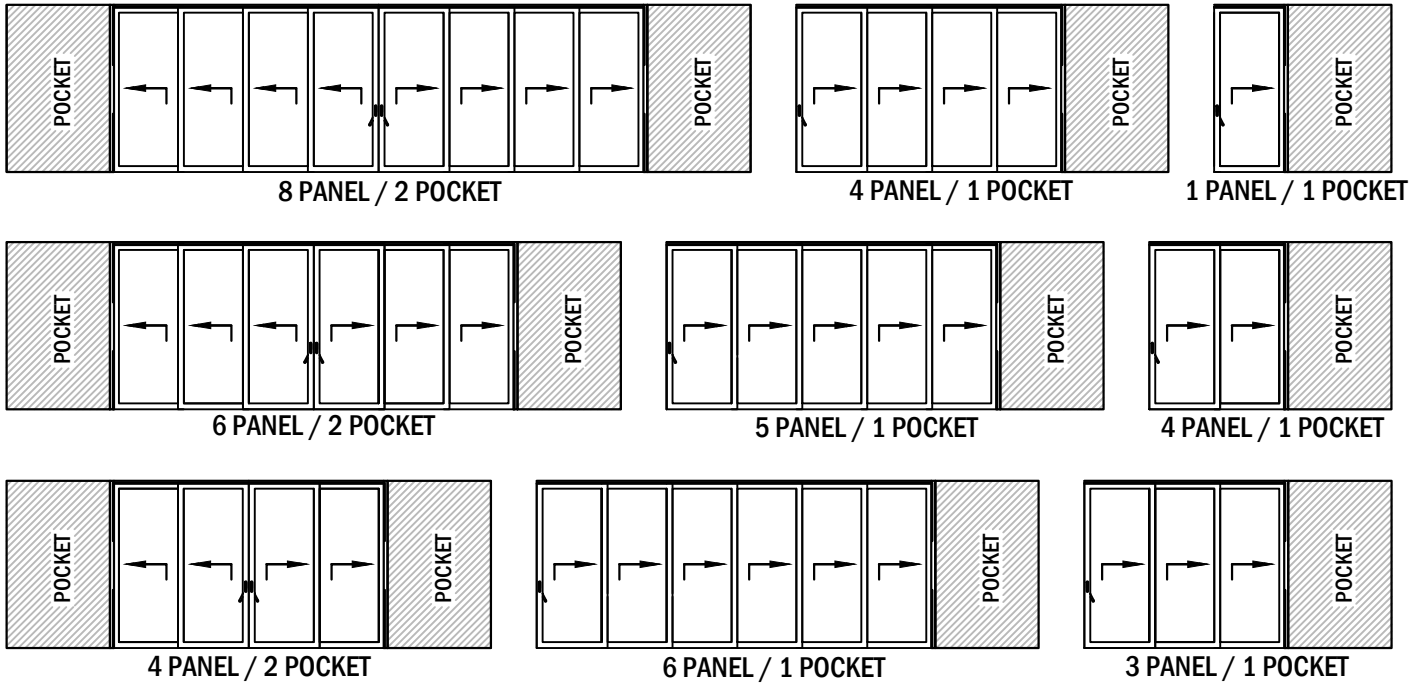

**PANEL CONFIGURATION WITH FIXED PANEL** (SYSTEM CAN STACK LEFT AND/OR RIGHT)

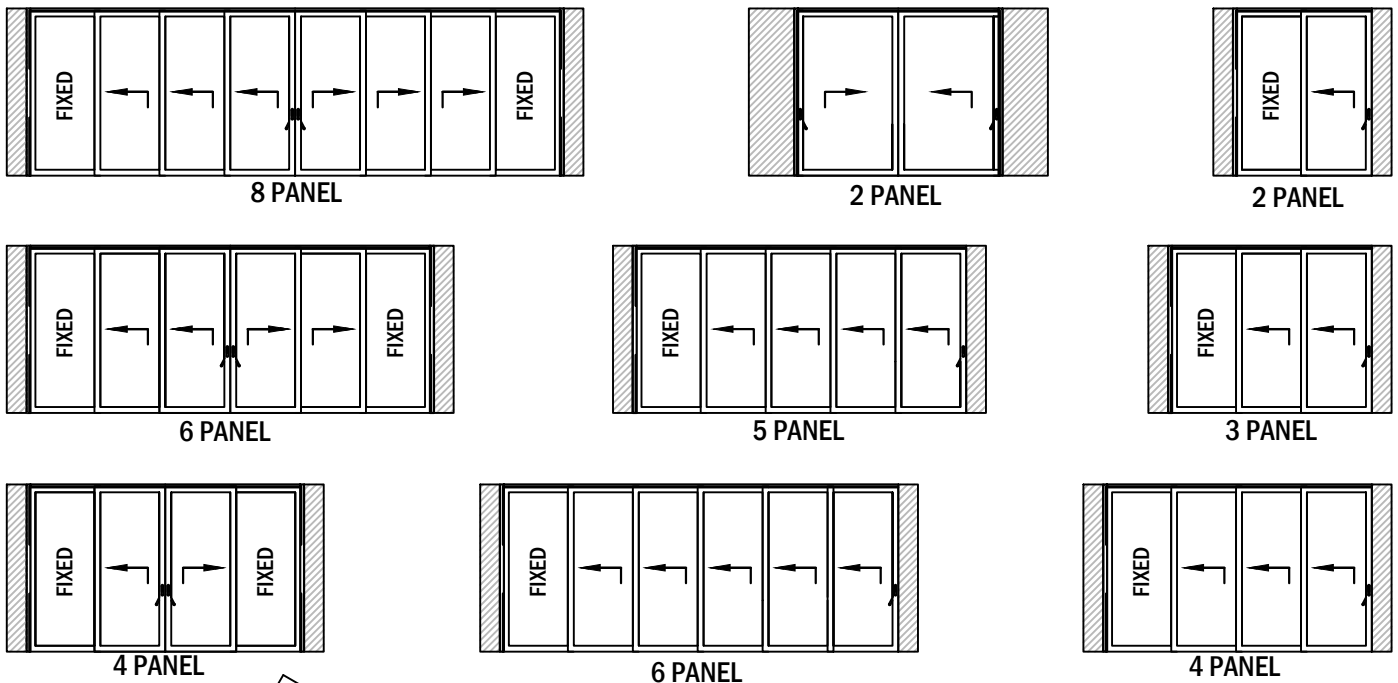



**OPTION 1**

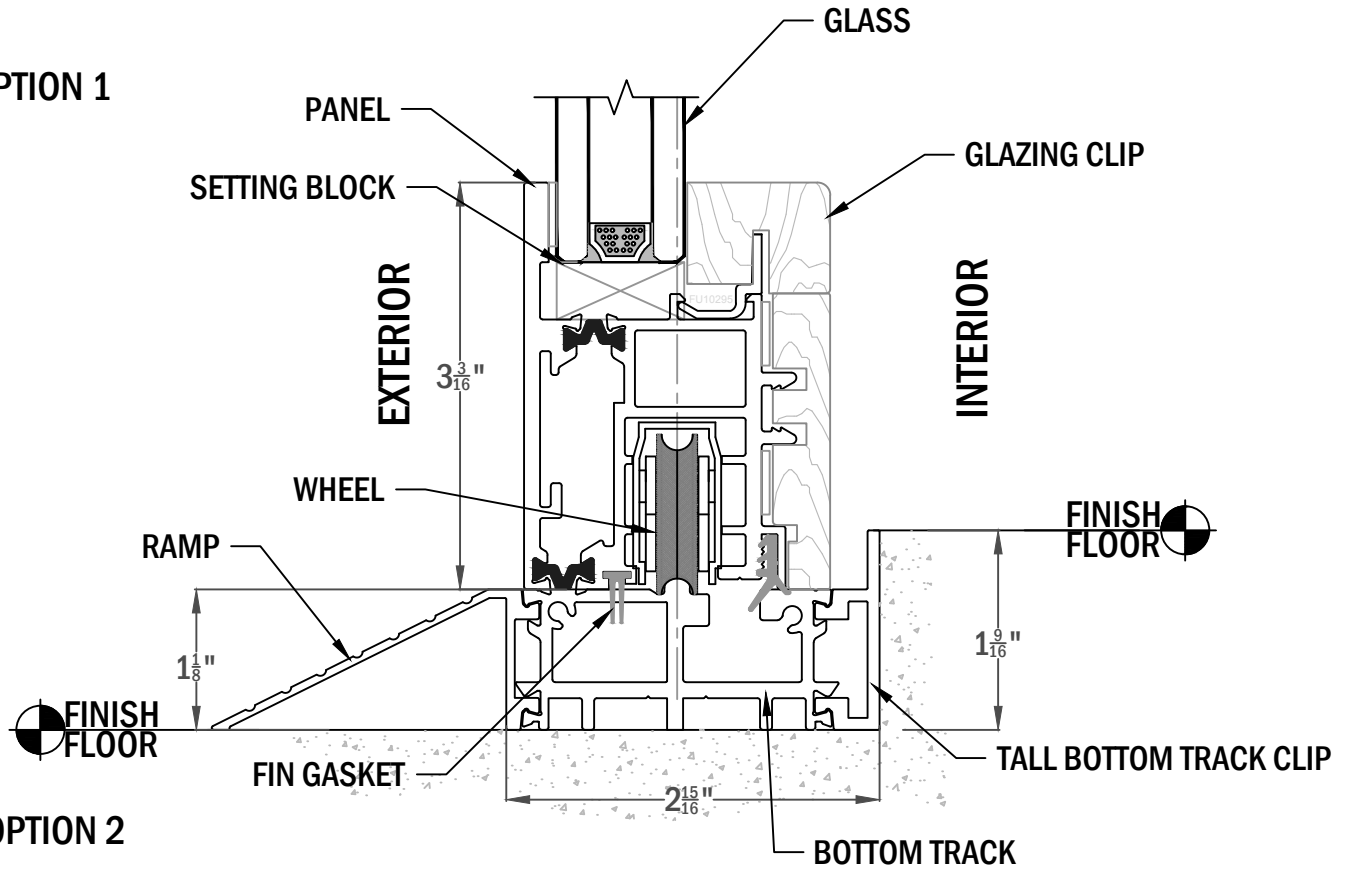

**OPTION 2**

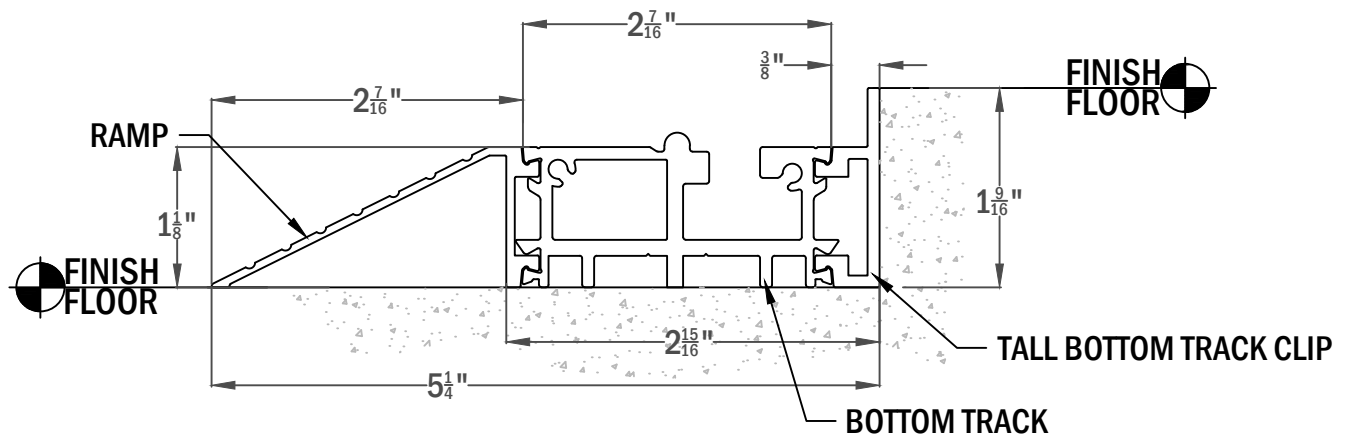

**OPTION 3**

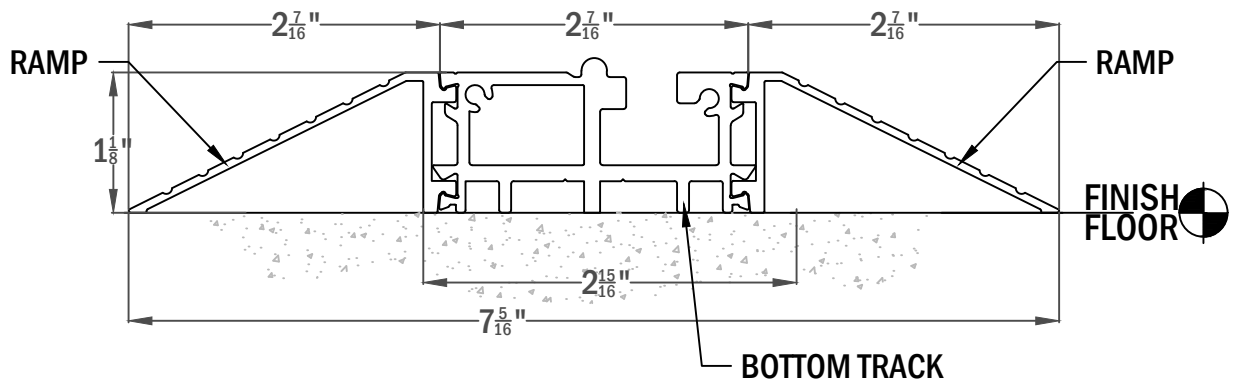



**RECOMMENDED TRENCH WIDTH:**

- 1 TRACK:  $3\frac{5}{8}$ " WIDE
- 2 TRACK:  $6\frac{9}{16}$ " WIDE
- 3 TRACK:  $9\frac{1}{2}$ " WIDE
- 4 TRACK:  $12\frac{3}{8}$ " WIDE
- 5 TRACK:  $15\frac{5}{16}$ " WIDE

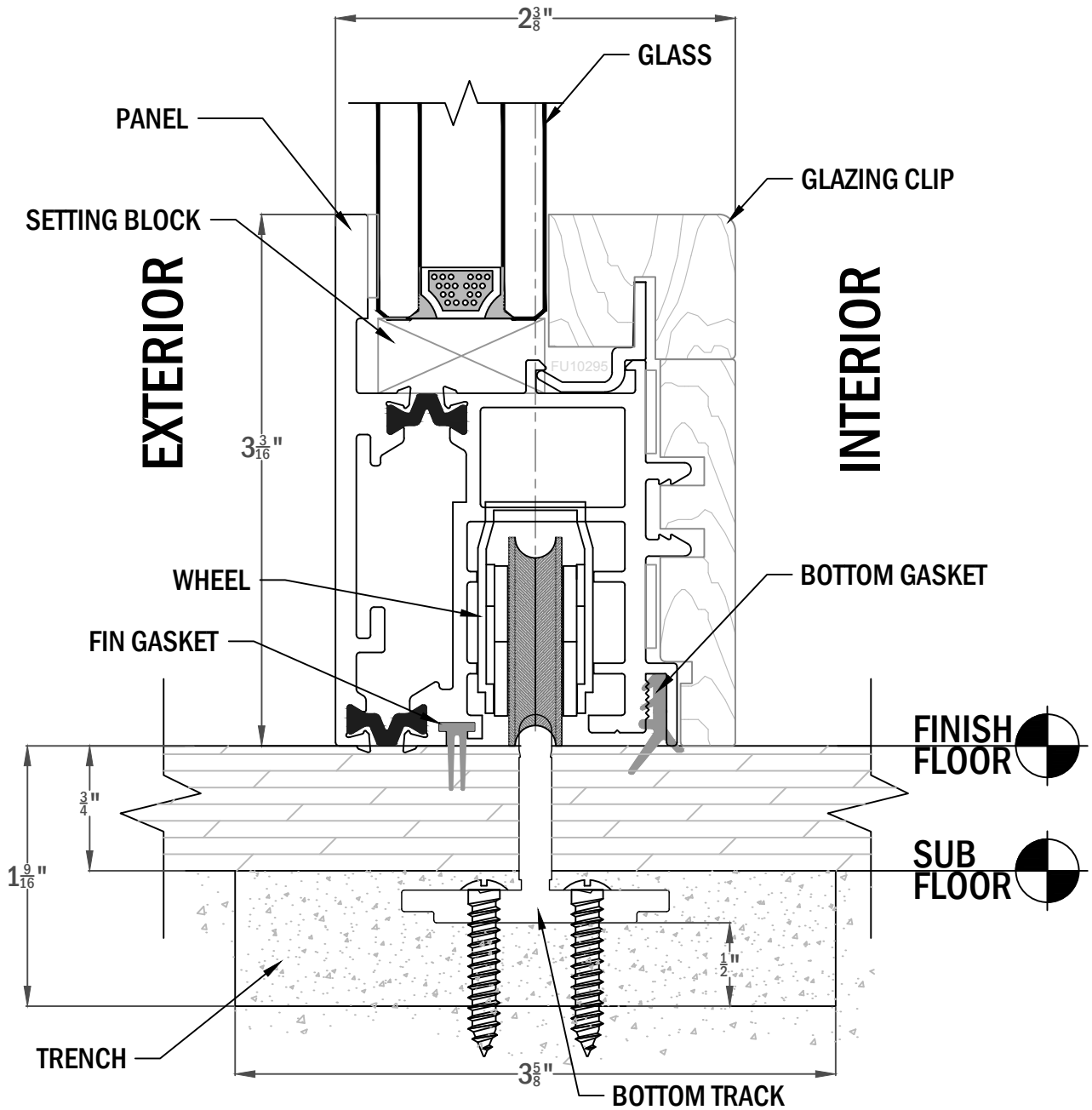



**RECOMMENDED TRENCH WIDTH:**

1 TRACK:  $3\frac{3}{4}$ " WIDE

2 TRACK:  $6\frac{11}{16}$ " WIDE

3 TRACK:  $9\frac{5}{8}$ " WIDE

4 TRACK:  $12\frac{9}{16}$ " WIDE

5 TRACK:  $15\frac{7}{16}$ " WIDE

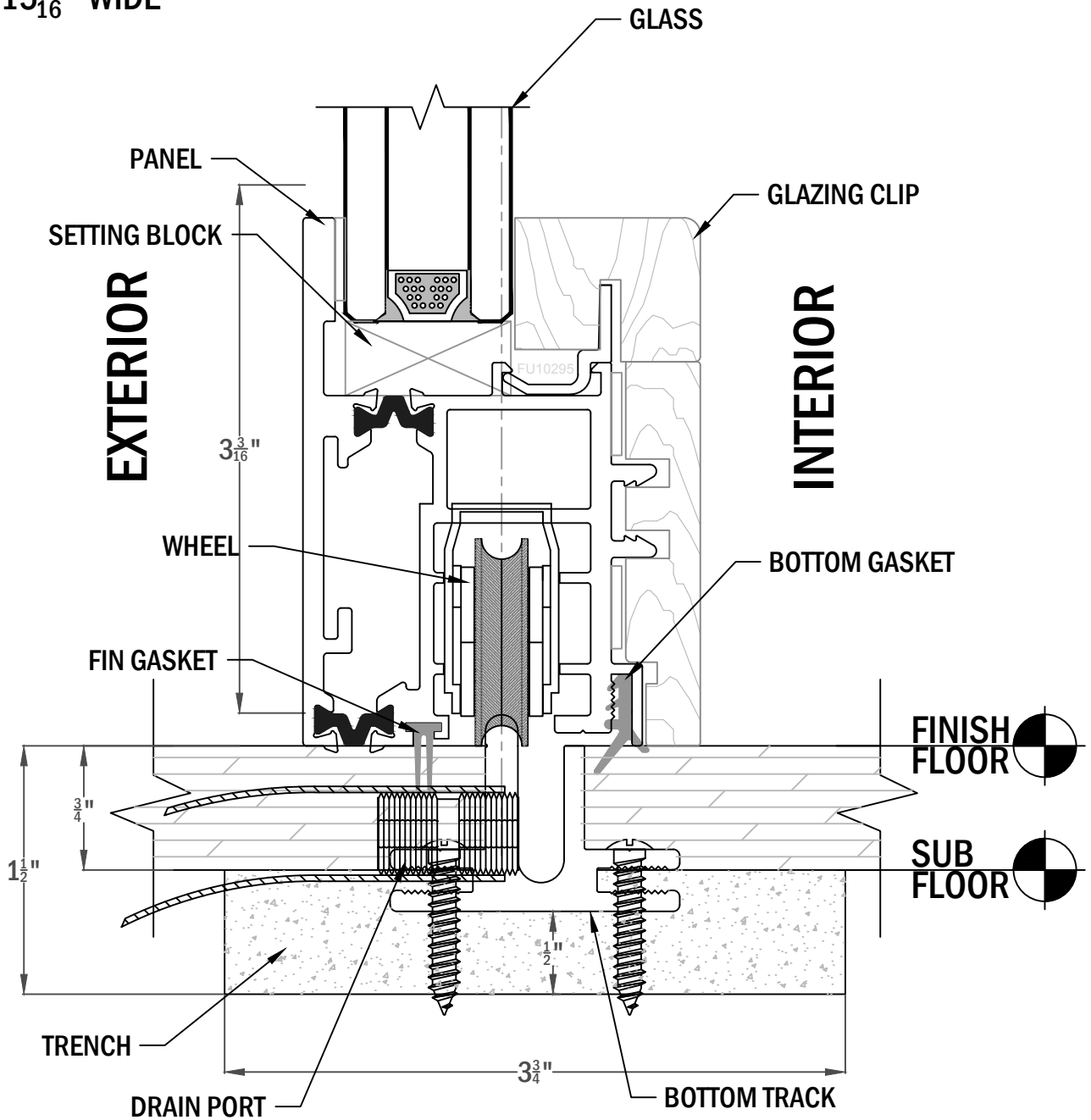



**RECOMMENDED TRENCH WIDTH:**

- 1 TRACK: 6 <sup>3</sup>/<sub>8</sub>" WIDE
- 2 TRACK: 9 <sup>5</sup>/<sub>16</sub>" WIDE
- 3 TRACK: 12 <sup>1</sup>/<sub>4</sub>" WIDE
- 4 TRACK: 15 <sup>3</sup>/<sub>16</sub>" WIDE
- 5 TRACK: 18 <sup>1</sup>/<sub>8</sub>" WIDE

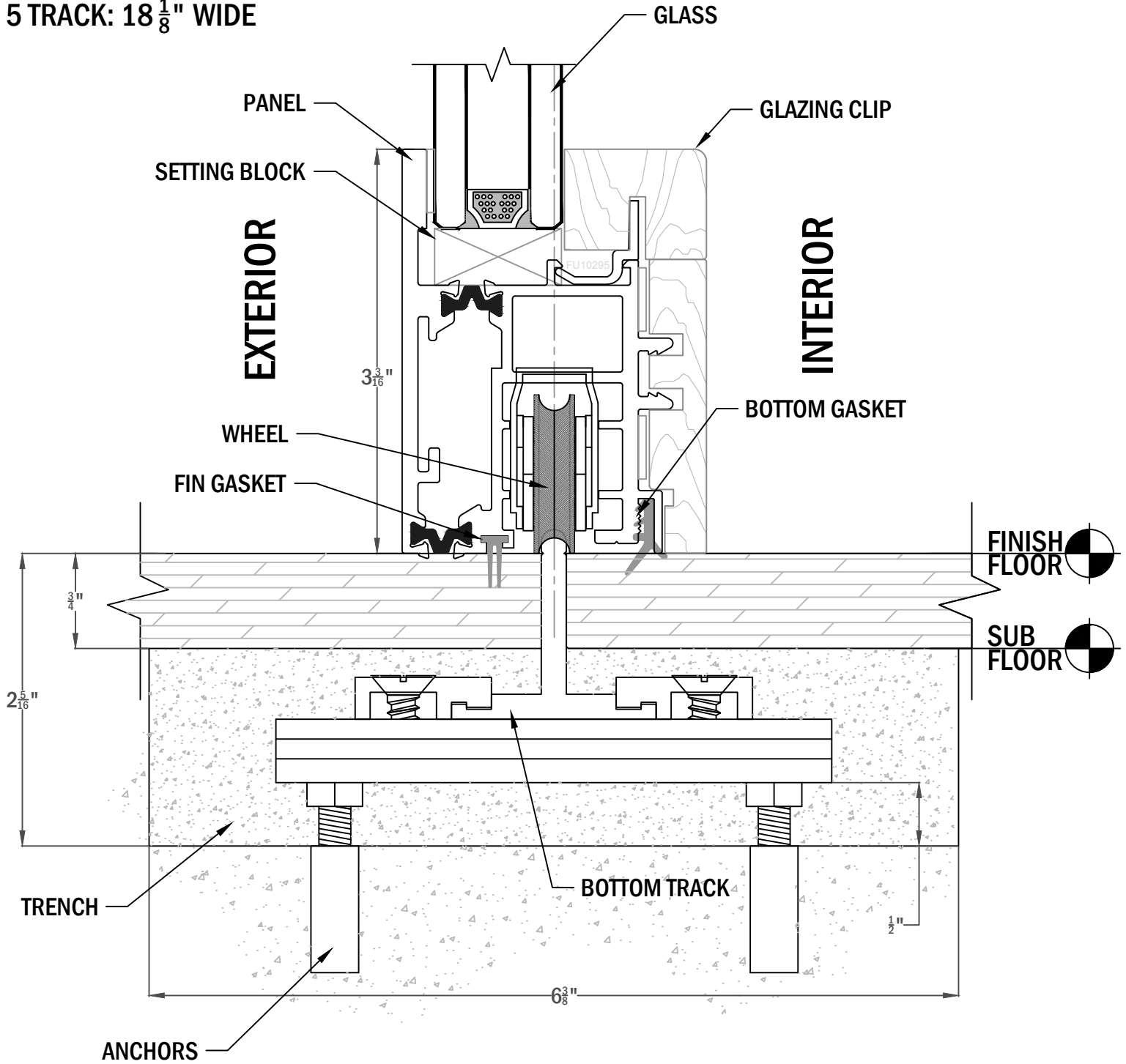



**RECOMMENDED TRENCH WIDTH:**

- 1 TRACK: 6 <sup>3</sup>/<sub>8</sub>" WIDE
- 2 TRACK: 9 <sup>5</sup>/<sub>16</sub>" WIDE
- 3 TRACK: 12 <sup>1</sup>/<sub>4</sub>" WIDE
- 4 TRACK: 15 <sup>3</sup>/<sub>16</sub>" WIDE
- 5 TRACK: 18 <sup>1</sup>/<sub>8</sub>" WIDE

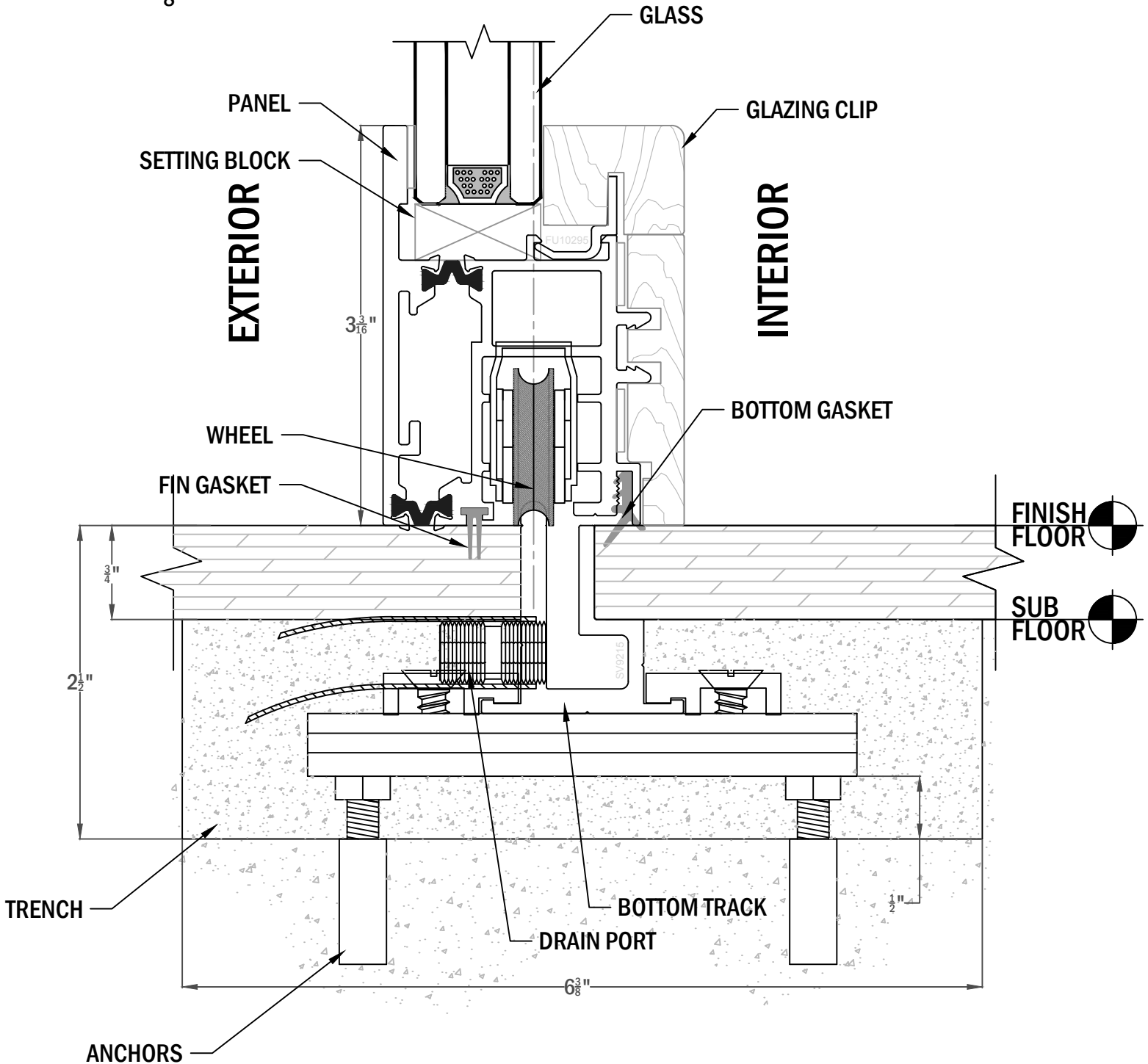



**HEADER WIDTH:**

- 1 PANEL:  $2\frac{15}{16}$ " WIDE
- 2 PANELS:  $5\frac{7}{8}$ " WIDE
- 3 PANELS:  $8\frac{13}{16}$ " WIDE
- 4 PANELS:  $11\frac{3}{4}$ " WIDE
- 5 PANELS:  $14\frac{11}{16}$ " WIDE

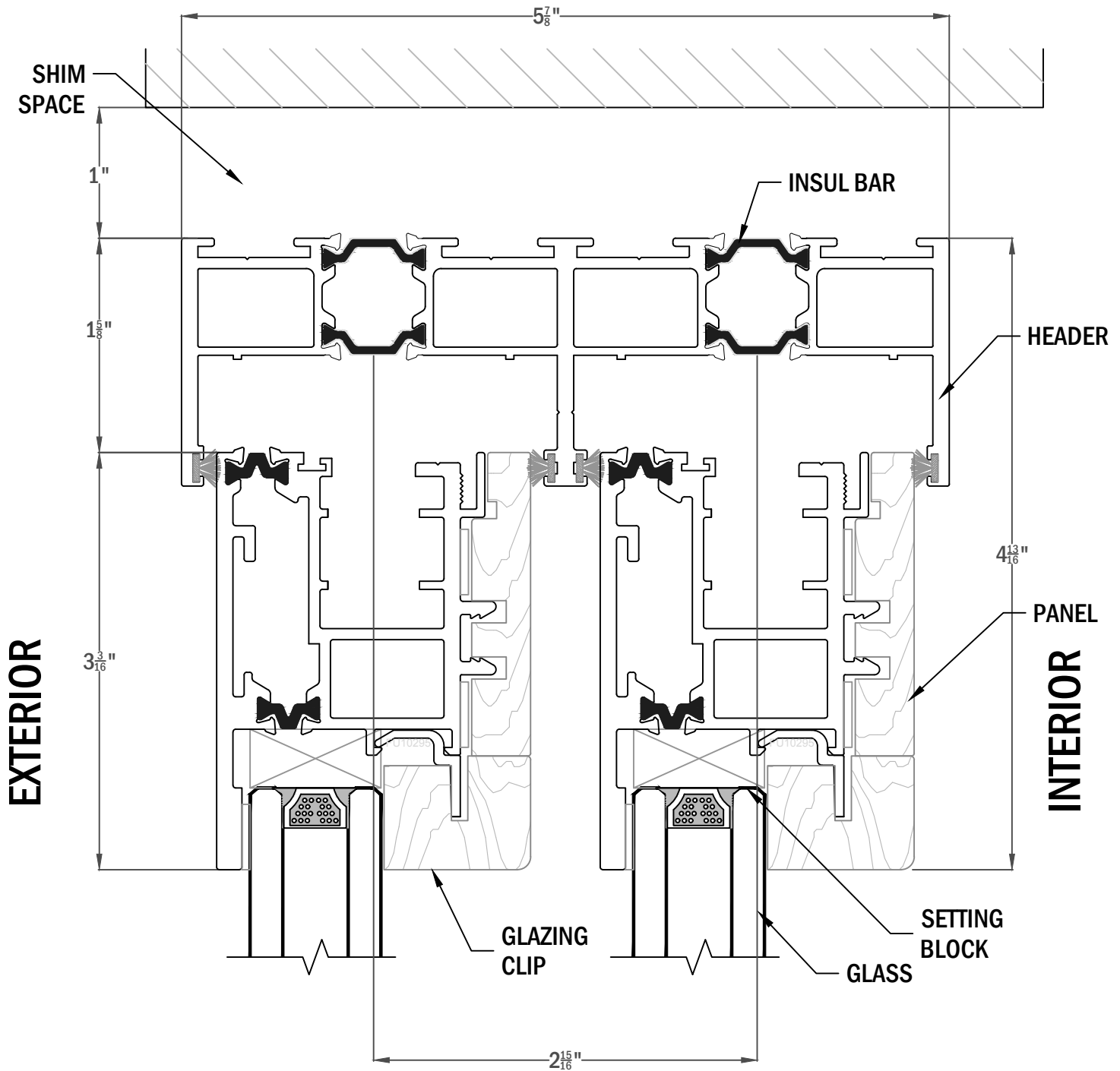





**SIDE FRAME WIDTH:**

- 1 PANEL:  $2\frac{15}{16}$ " WIDE
- 2 PANELS:  $5\frac{7}{8}$ " WIDE
- 3 PANELS:  $8\frac{13}{16}$ " WIDE
- 4 PANELS:  $11\frac{3}{4}$ " WIDE
- 5 PANELS:  $14\frac{11}{16}$ " WIDE

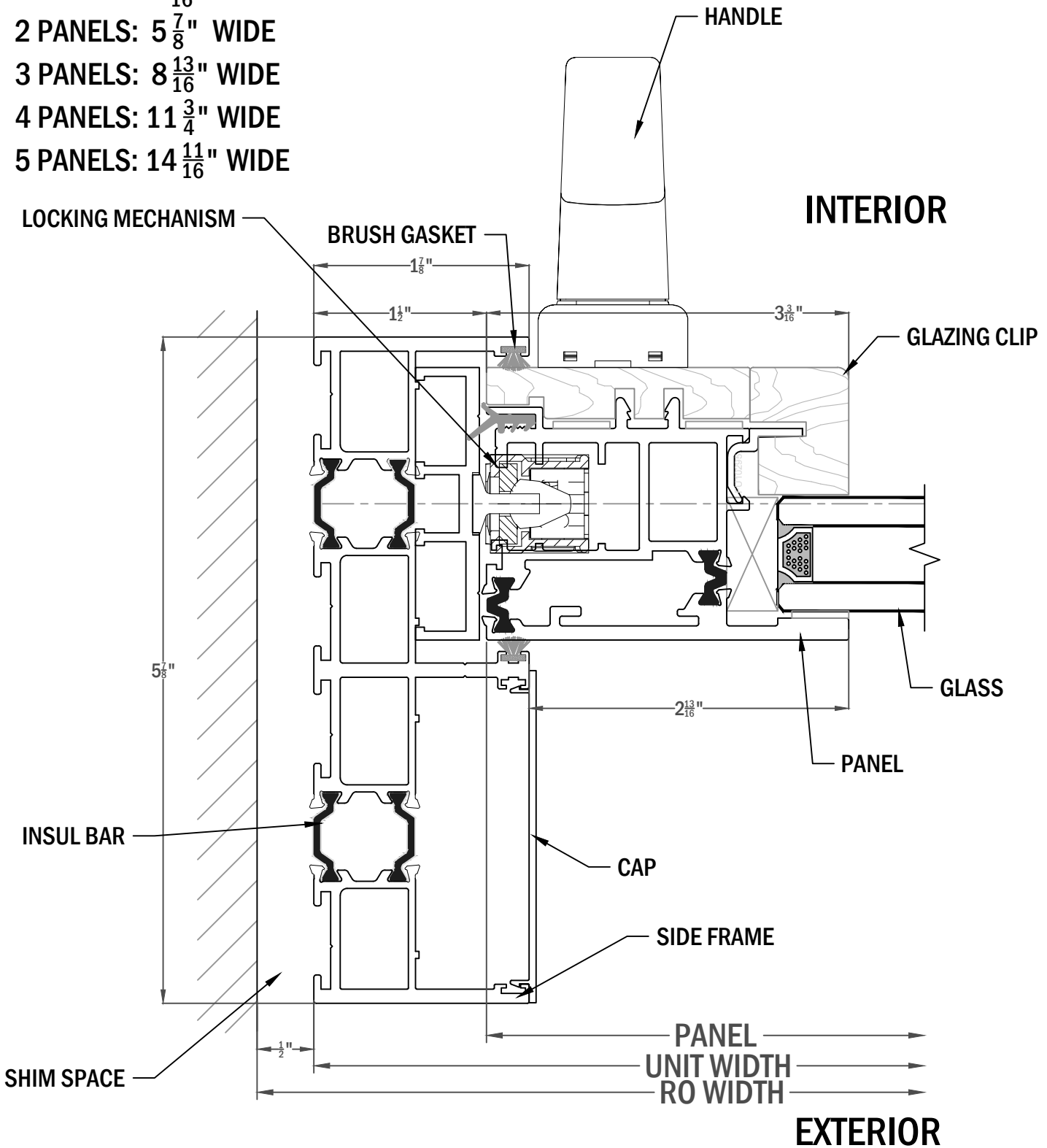

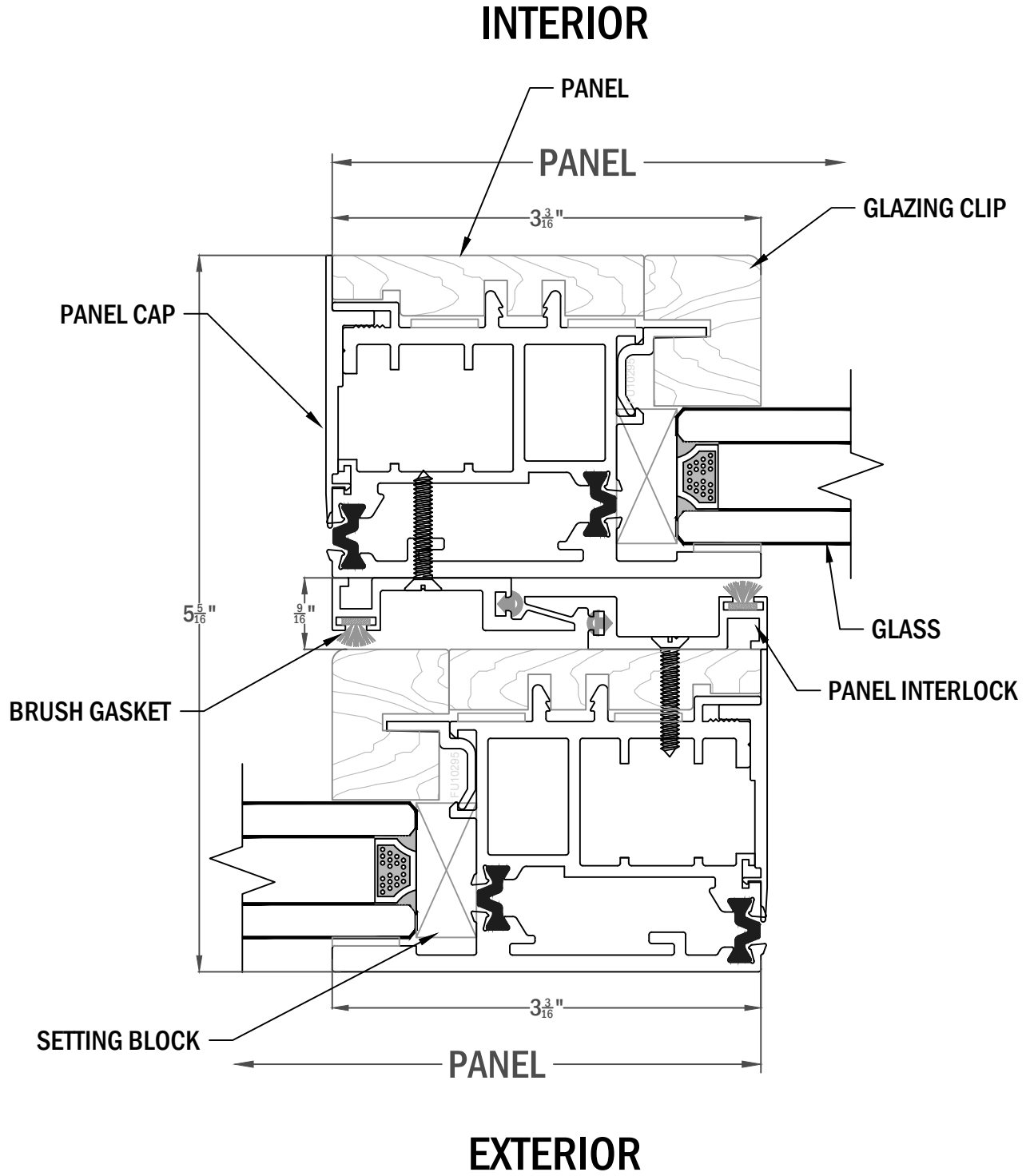

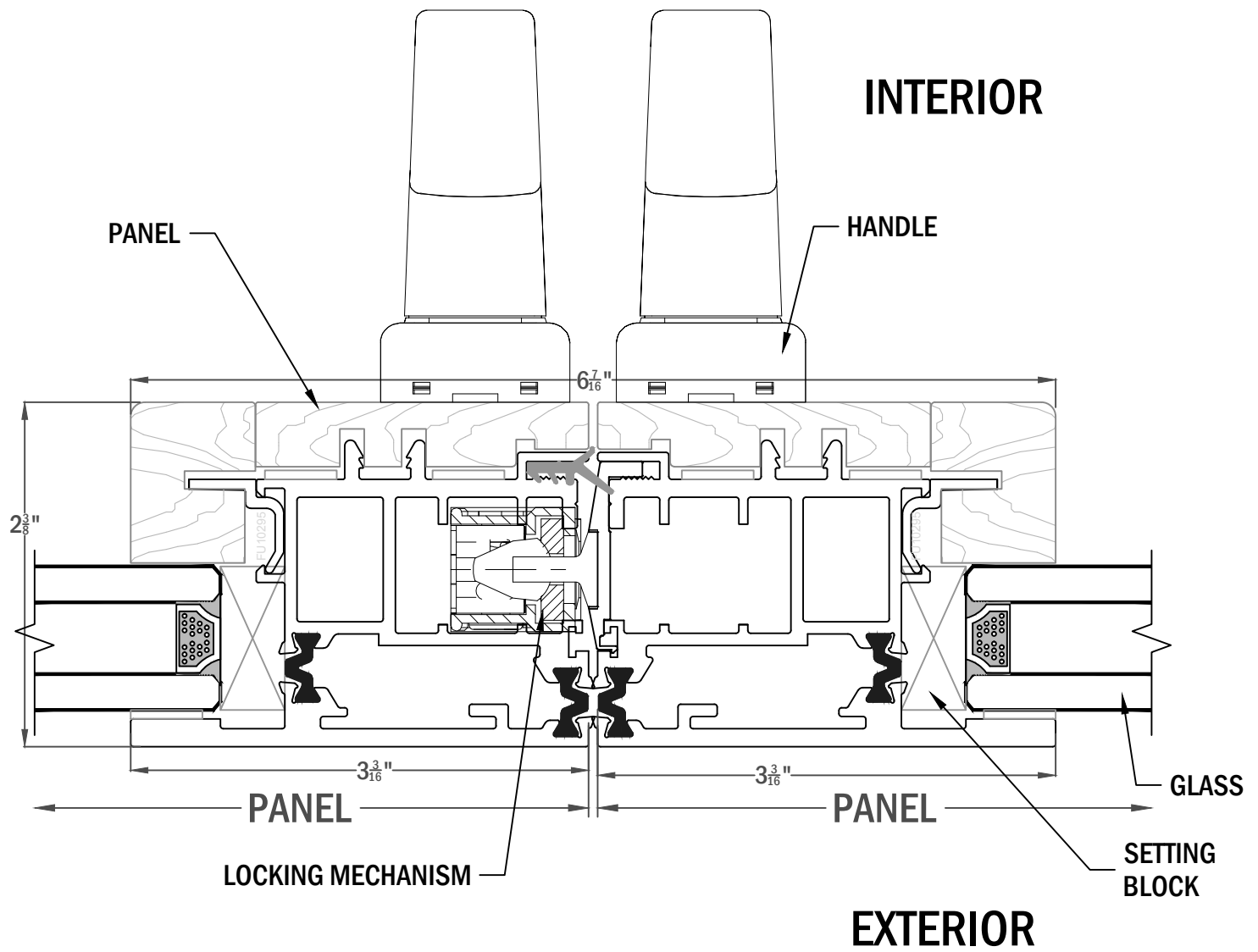



**RECOMMENDED POCKET WIDTH:**

- 1 PANEL:  $3 \frac{7}{16}$ " WIDE
- 2 PANELS:  $6 \frac{5}{8}$ " WIDE
- 3 PANELS:  $9 \frac{9}{16}$ " WIDE
- 4 PANELS:  $12 \frac{1}{2}$ " WIDE
- 5 PANELS:  $15 \frac{7}{16}$ " WIDE

