



### **Profiles:**

The profiles are made from 6063-T5 extruded aluminum for strength and durability. Due to the strength of these extrusions they are the perfect alternative to steel for oversized openings. The custom designed bottom sill plate offers minimal rise with maximum weather resistance.

### **FINISHES:**

All of Panda's door and window systems are available in Powder Coat, Kynar or Anodized finishes, offered in unlimited custom color options.

### **ACCESSORIES:**

There is a variety of standard and custom hardware options to choose from with different finishes to meet your project specifications.

### **GLAZING:**

Doors are available with variety of dividers and mullions. 1" thick glass is available to meet design & climate needs.

### **SECURITY:**

All Pivot doors come standard with stainless steel multi-point locking hardware for maximum intrusion resistance.

### **DIMENSION:**

Pivot doors may be up to 8' wide & 14' in height.

### **Weight:**

Each panel weighs approximately 7 to 8 lbs per square foot.



DOOR CONFIGURATIONS

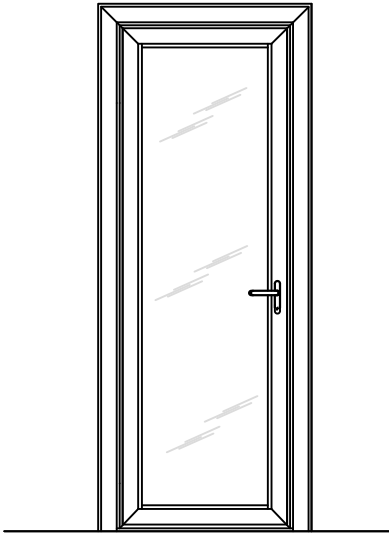

SINGLE DOOR

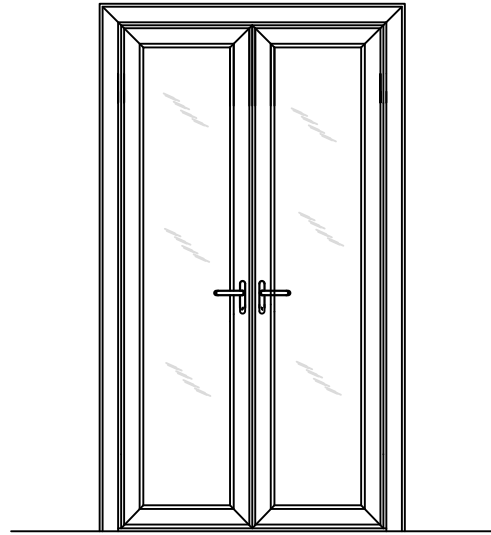

DOUBLE DOOR

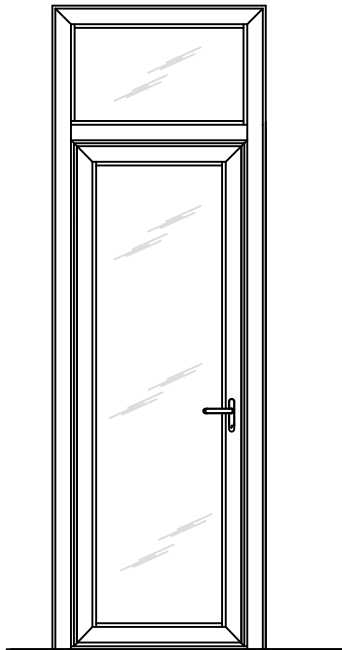

SINGLE DOOR  
W/FIXED TRANSOM



DOUBLE DOOR  
W/FIXED DOORS



**INSWING**

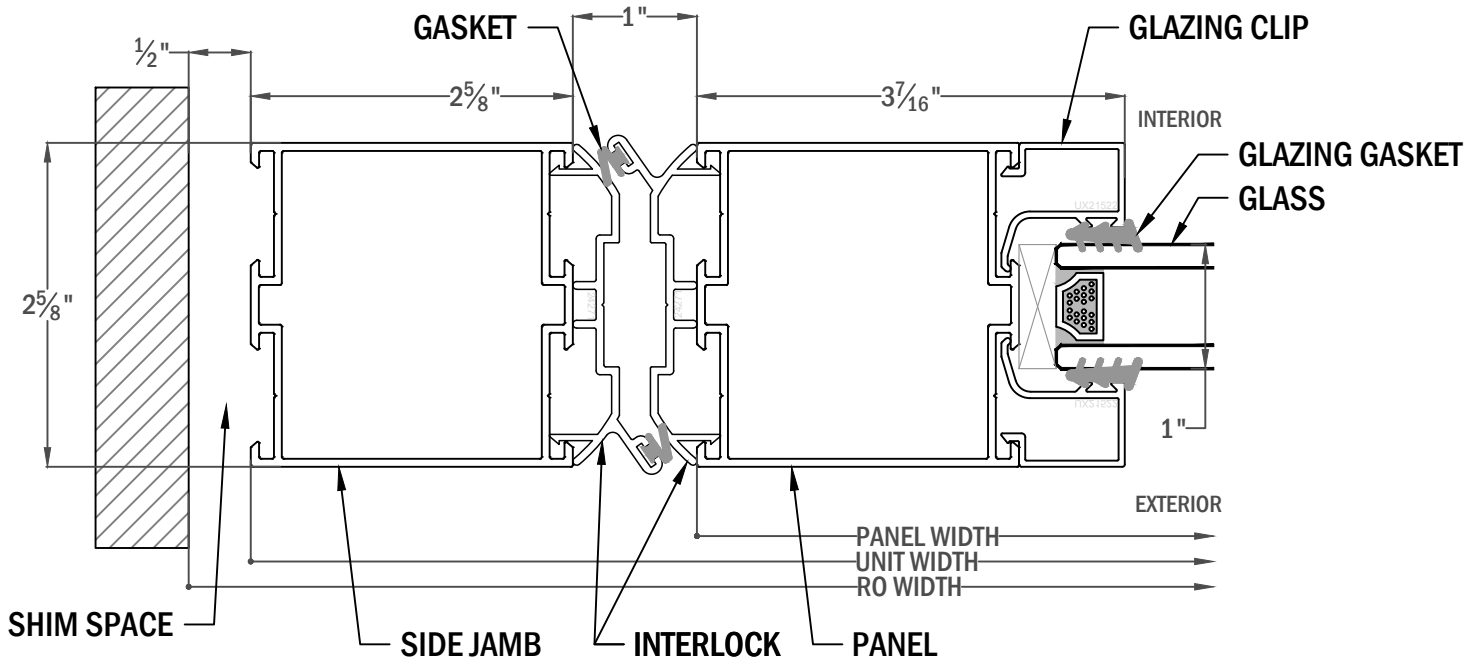

**OUTSWING**

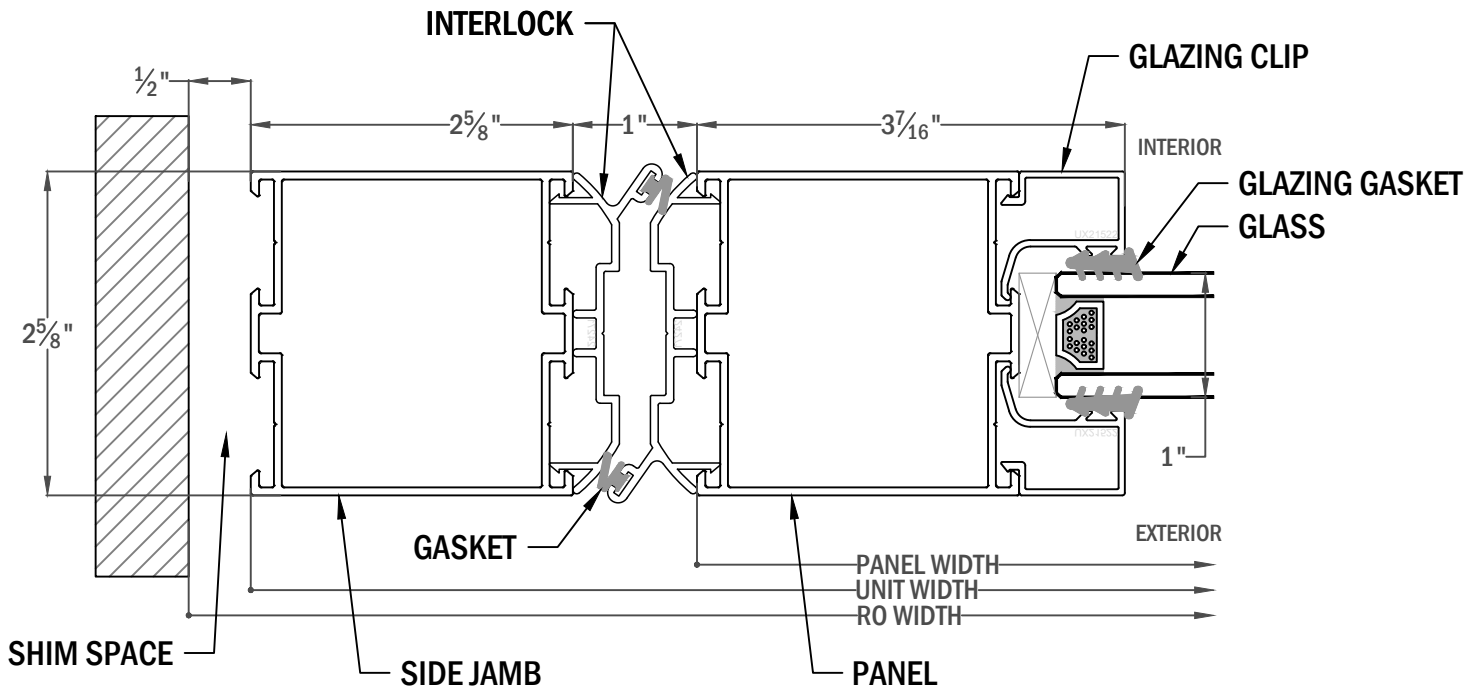



### INSWING

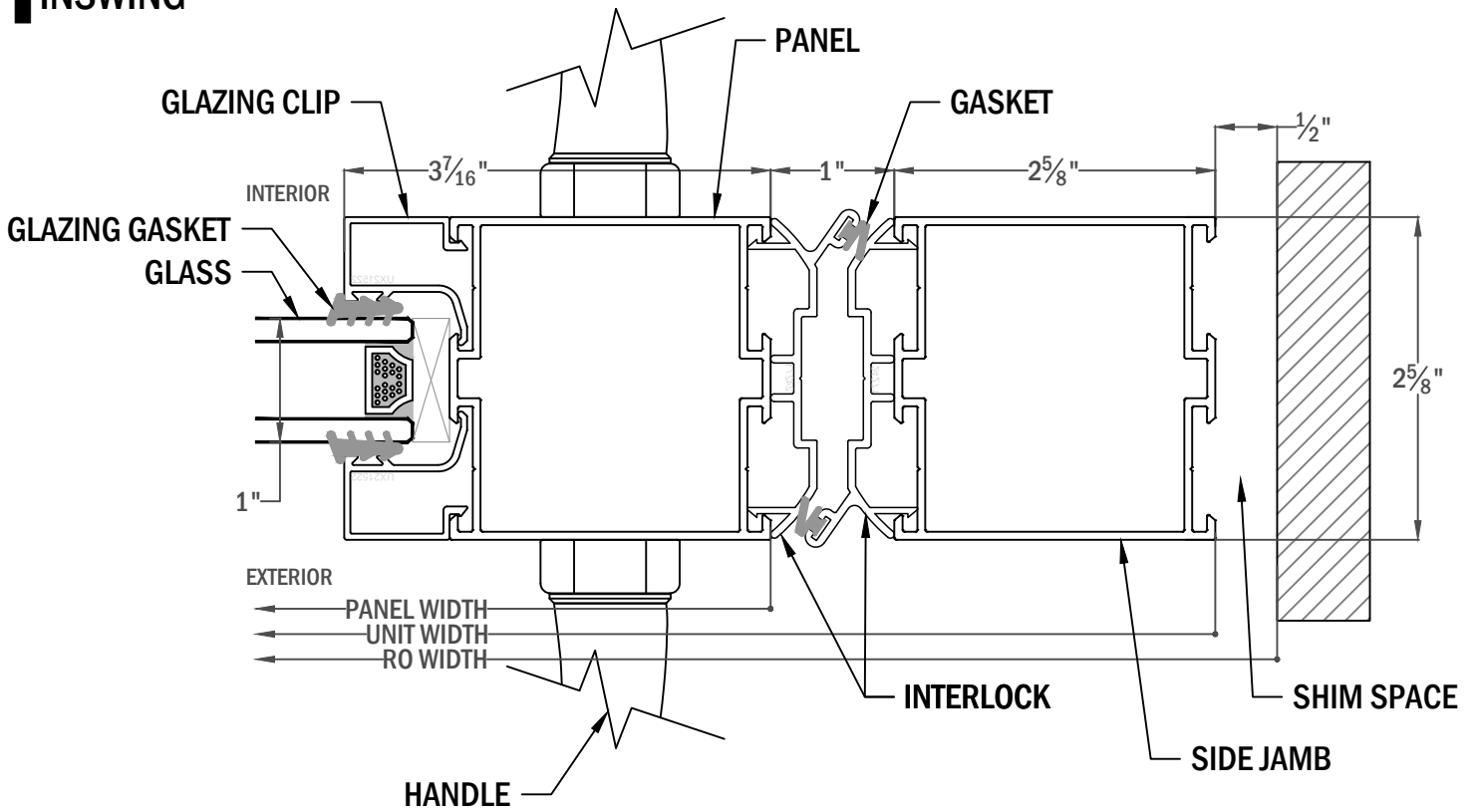

### OUTSWING

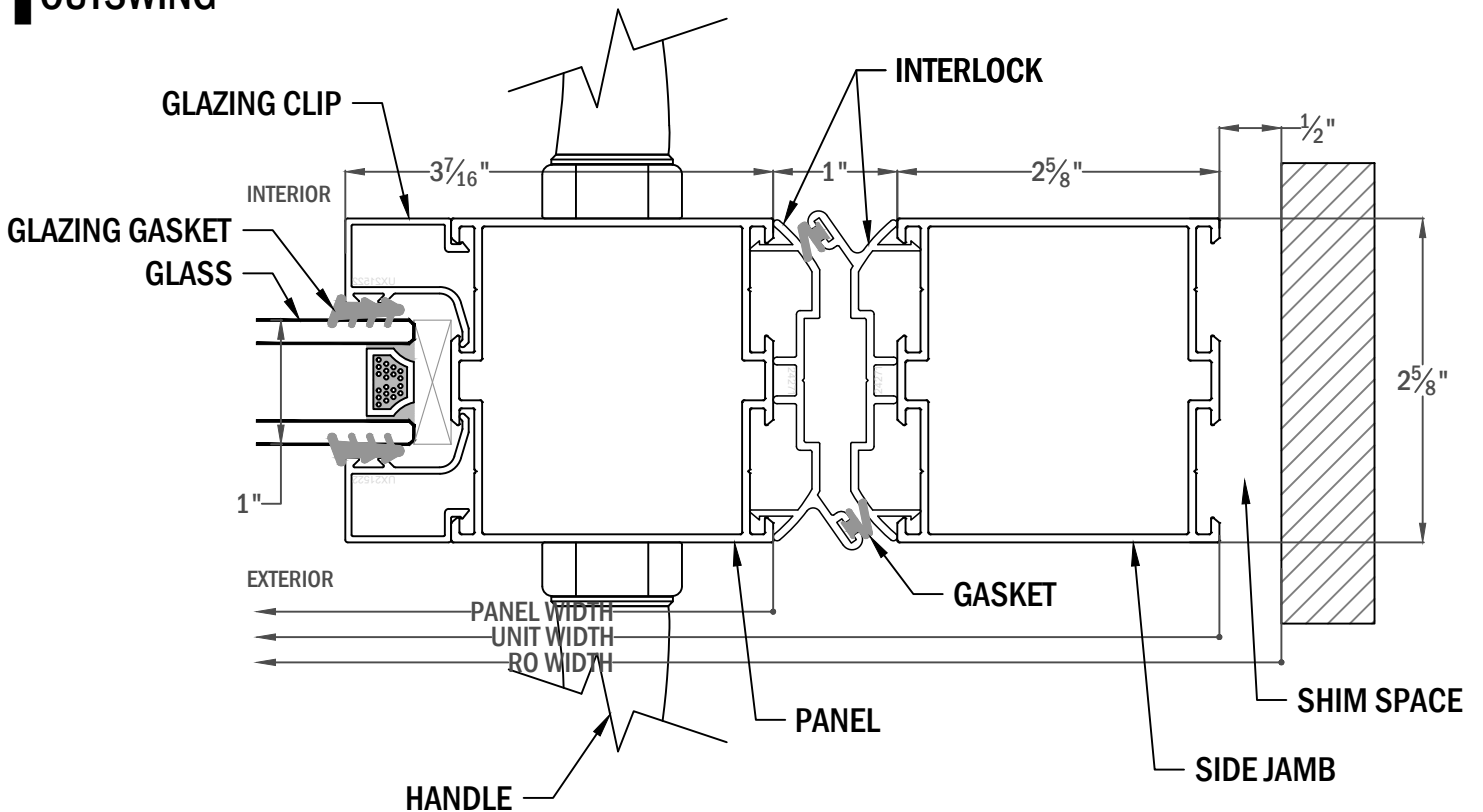



### INSWING

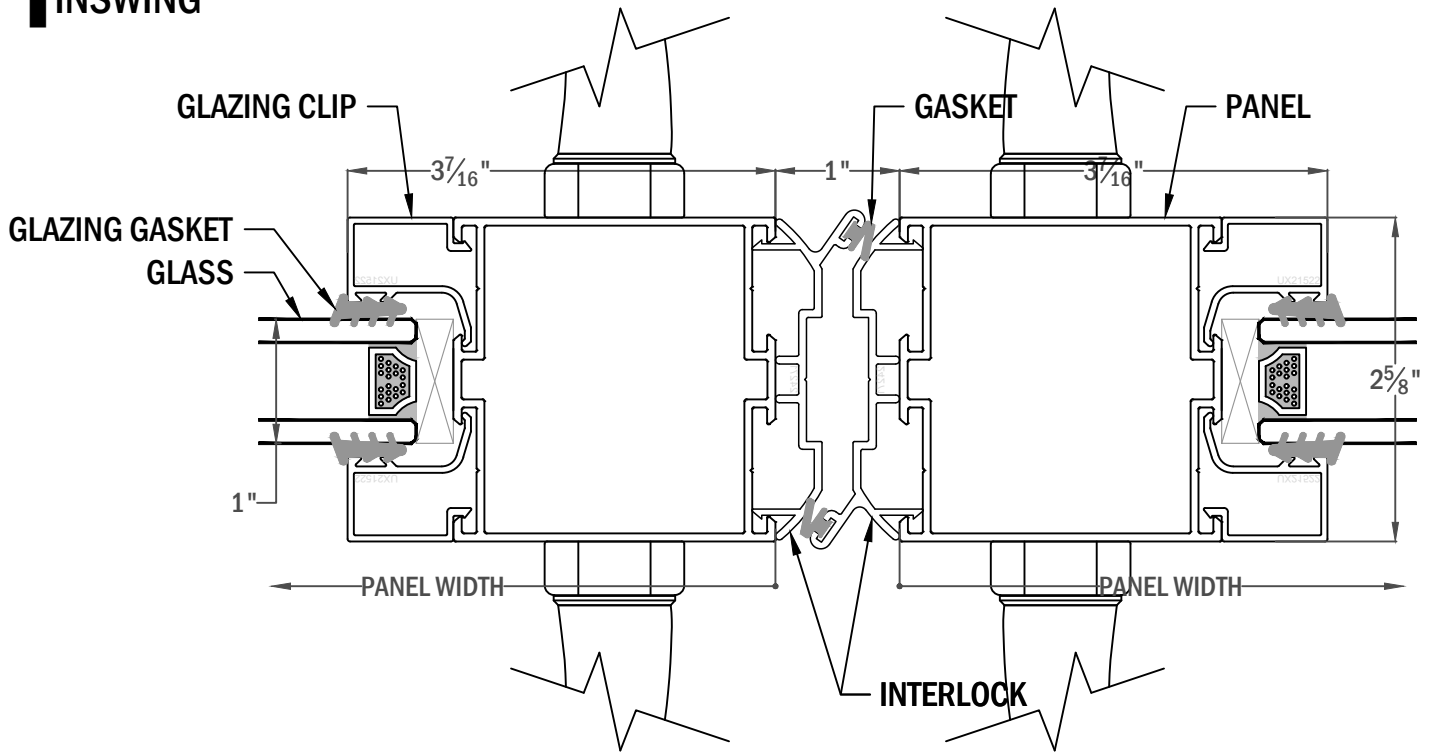

### OUTSWING

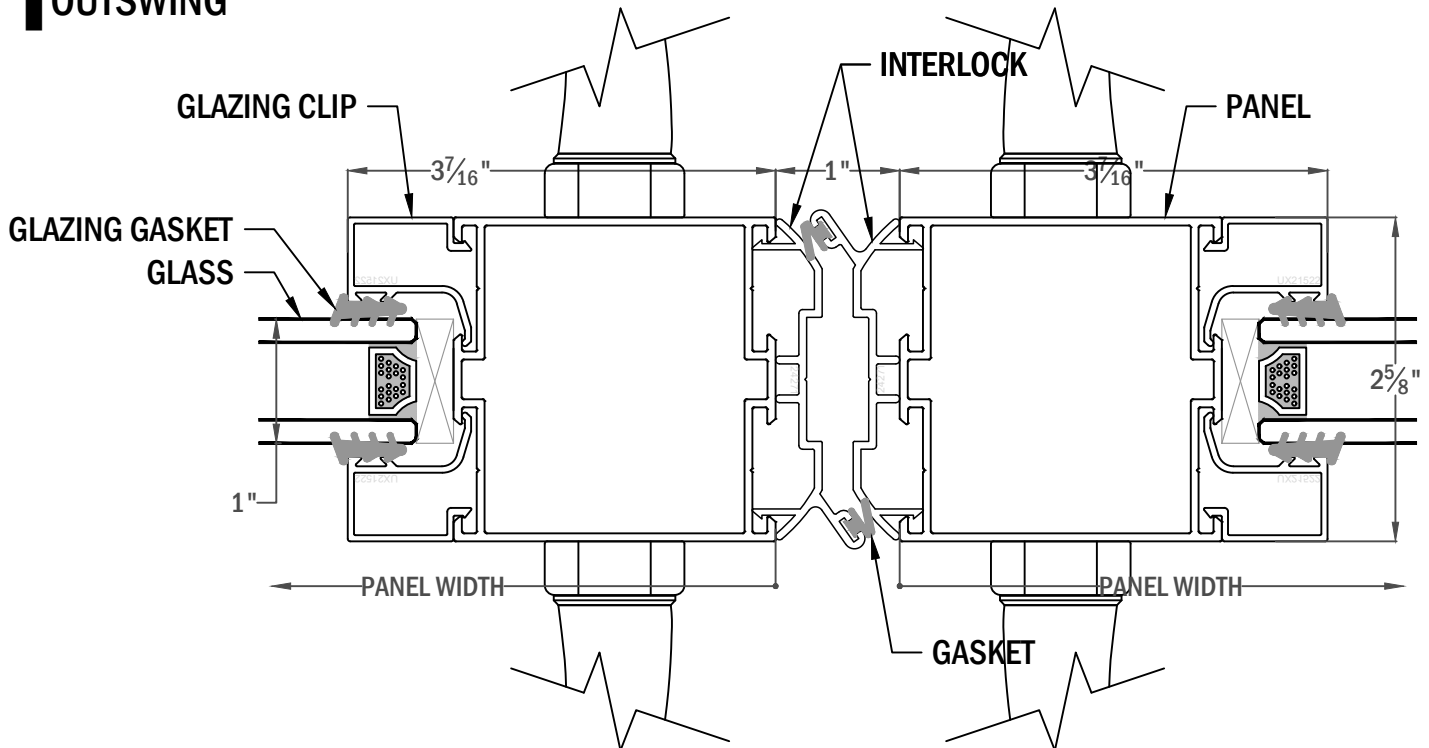



### INSWING

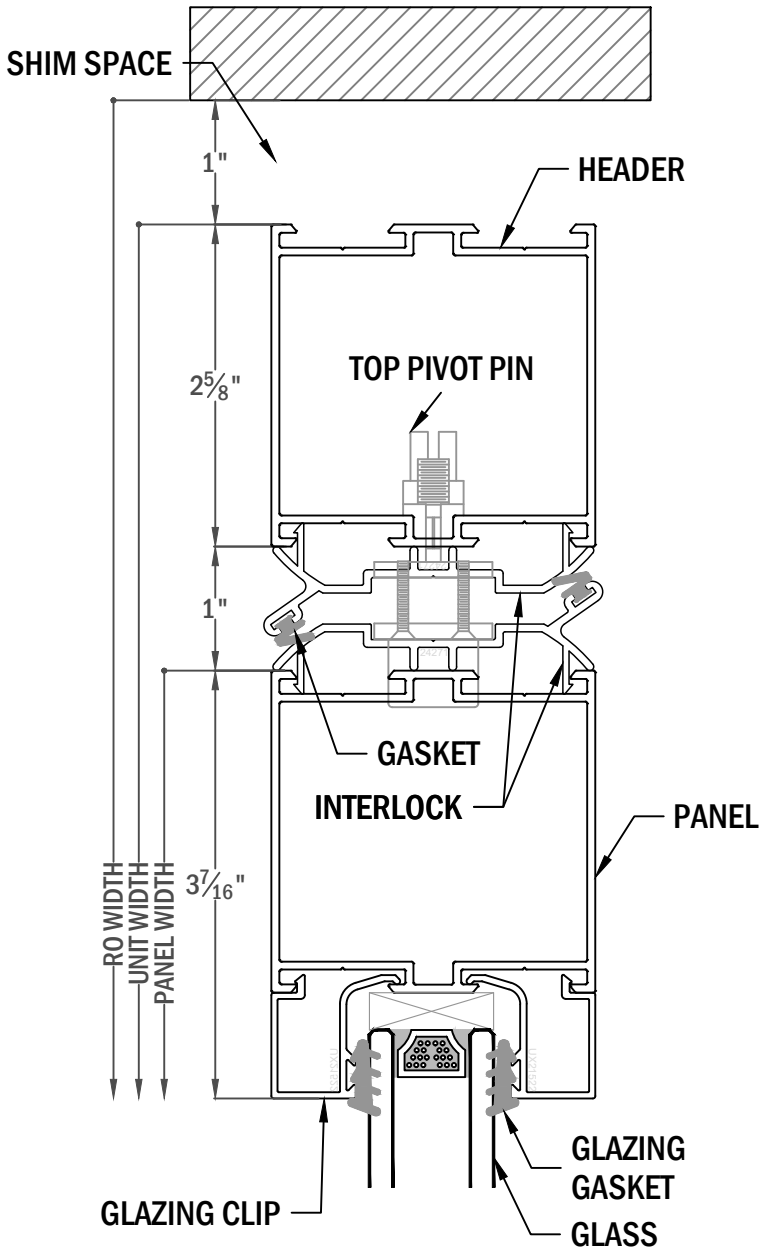

### OUTSWING

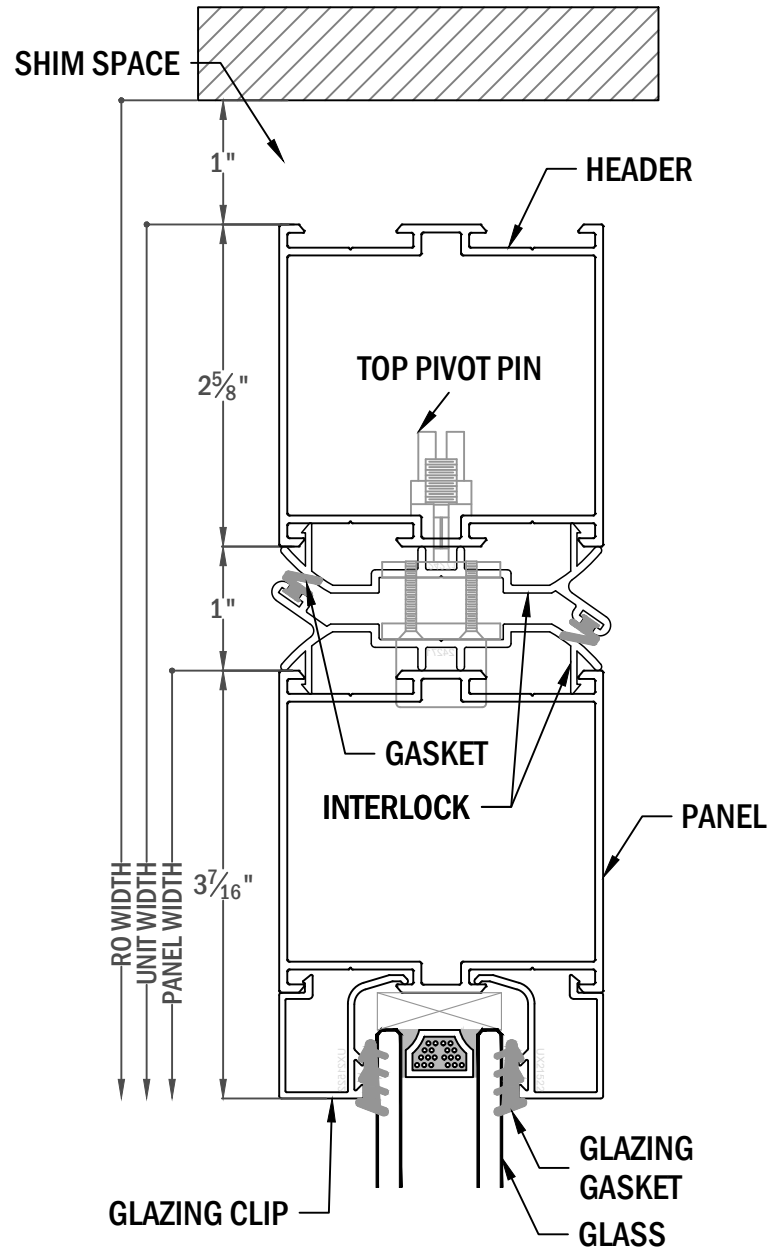



**3/8" TB SURFACE TRACK W/PIVOT**

